

SVI SERIES

SUBMERSIBLE VERTICAL ELECTRIC PUMPS

APPLICATIONS

- Pumping of coolants, lubricants and condensate.
- Machine tools, welders, engine test stands.
- Cooling systems.
- Washing systems.
- Boosters.
- Fire-fighting systems.

SPECIFICATIONS

PUMP

- **Delivery:** up to **72 m³/h.**
- **Head:** up to **247 m.**
- **Liquid temperature:**
 - 10°C to +90°C for "S" and "N" versions with coupling,
 - 10°C to +60°C for close-coupled "E" versions.
- Maximum ambient temperature: +40°C.
- Tested in compliance with ISO 2548 for class C standard pumps.
- Rotation direction: clockwise when looking at pump end (indicated by the arrow on adapter and coupling).
- **Mechanical seal** in compliance with **DIN 24960 and ISO 3069** for "S" and "N" versions, LOWARA seal for "E" versions. Standard mechanical seal used for clean liquids. For applications with contaminated liquids there are available seals in Tungsten/Silicon/FPM or Tungsten Carbide/Silicon/FPM or Silicon/Silicon/FPM.
- Tank coupling flange in compliance with DIN 5440 and EN 12157.
- Standard installation in vertical position: however, all models (except the SVI 30 and 60 versions with over 5 stages at 50 Hz, and with over 4 stages at 60 Hz) can be installed horizontally.
- Reduced axial thrust allows standard motors to be used (for "S" and "N" versions).
- These pumps can handle clean liquids free of abrasive substances or fibres, with kinematic viscosities up to 37 mm²/sec., with suitably sized motor.
- Minimum level of suction liquid: 25mm for SVI 2-4-6-8-16 models and 100 mm for SVI 30 and 60 models.
- Suction base has filter with 2 mm. diameter holes (SVI 2-4) or 3 mm. holes (SVI 8-16-30-60).
- AISI 316 STAINLESS STEEL "N" version available for models SVI 2-4-8-16.



- Longer pump columns (from coupling flange to suction base) are available on request. Possible variants follow the number of upper stages indicated in each model's dimensions table.

MOTOR

- Squirrel cage, finned aluminium casing, enclosed construction with external ventilation.
- **IP55 protection.**
- **Class F insulation.**
- Performance in compliance with CEI 2-3 (IEC 34,1).
- **Construction design:**
 - Close-coupled for "E" version (LOWARA motor);
 - Standard motor for "S" and "N" V18 versions, for power up to 4 kW, and V1 versions for power above 4 kW.
- **Standard voltage:**
 - Single-phase** 220-240V - 50 Hz on request.
 - Three-phase** 220-240/380-415 V - 50 Hz with power up to 3 kW;
 - 380-415 V - 50 Hz with power up above 23 kW.

SVI SERIES OPERATING CHARACTERISTICS AT 2900 rpm 50 Hz

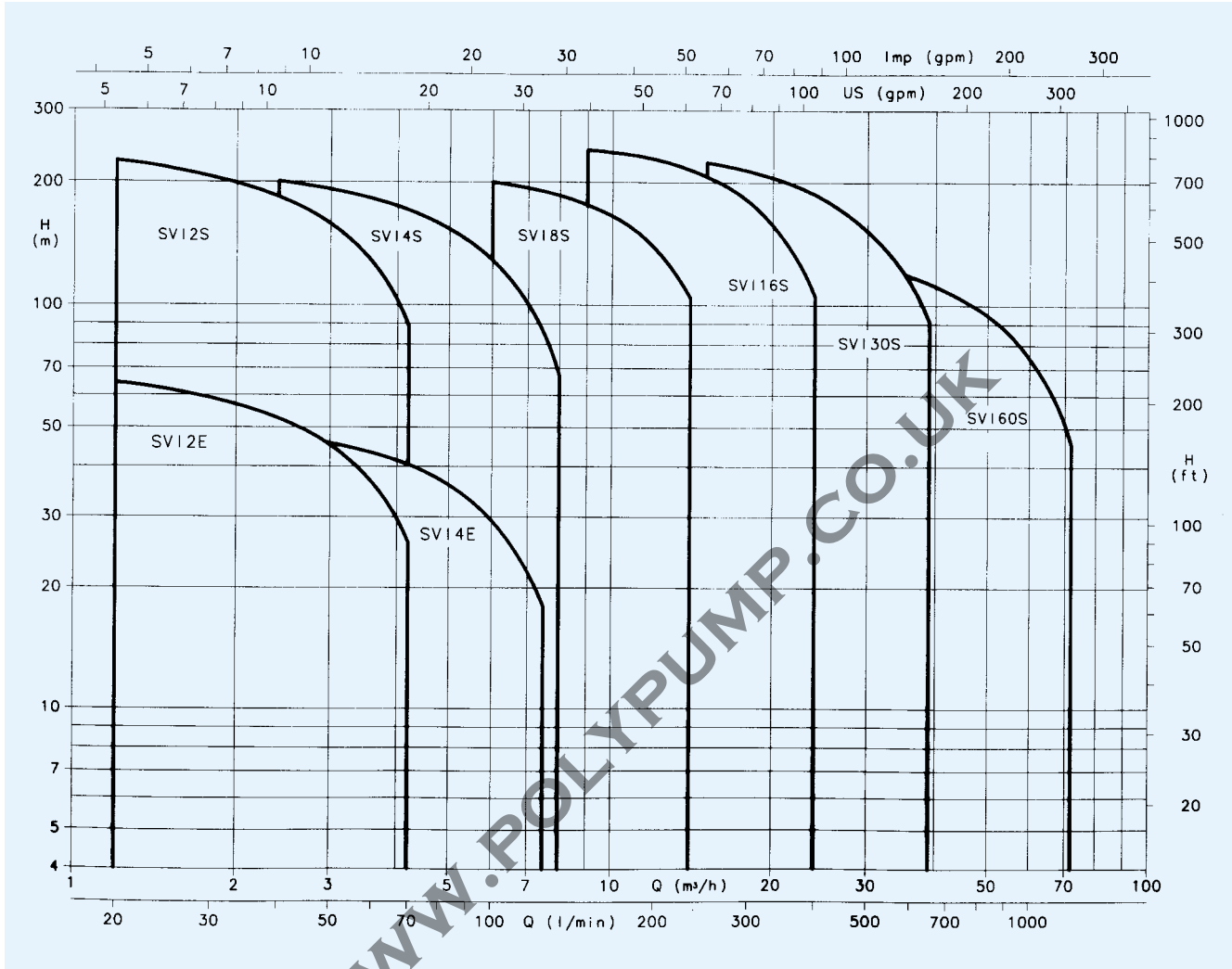

These performances are valid for liquids with density $\rho = 1.0 \text{ kg/dm}^3$ and kinematic viscosity $\gamma = 1 \text{ mm}^2/\text{sec}$.

MINIMUM IMMERSION LEVEL

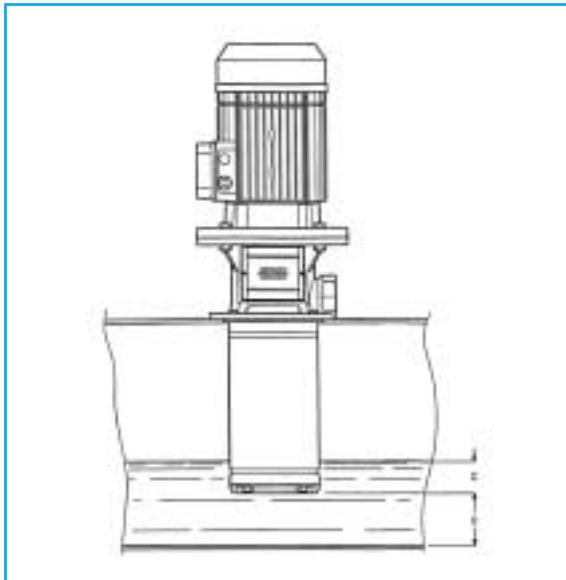

PUMP TYPE	DIMENSIONS IN mm C	DISTANCE FROM THE BOTTOM D mm	
		MINIMUM	RECOMMENDED
SVI 2	25	20	60
SVI 4	25	20	60
SVI 8	25	35	80
SVI 16	25	35	80
SVI 30	100	80	120
SVI 60	100	80	120