

SV SERIES

VERTICAL MULTISTAGE CENTRIFUGAL PUMPS

Highly reliable and technologically advanced multipurpose pumps capable of satisfying the needs of a wide variety of users. Many different construction designs are available, with models featuring 2-4-8-16-30-60 m³/h nominal capacities.

- ❑ **HIGH HYDRAULIC EFFICIENCY**
- ❑ **LIQUID END MANUFACTURED IN AISI 304 STAINLESS STEEL FOR THE 2-4-8-16 m³/h STANDARD VERSION**
- ❑ **"N" VERSION AVAILABLE MADE OF AISI 316 STAINLESS STEEL**
- ❑ **VERSIONS WITH 4-POLE AND/OR 60 Hz MOTOR ARE AVAILABLE ON REQUEST**
- ❑ **MOTOR CAN BE REPLACED WITH ANY STANDARD MODEL AVAILABLE ON THE MARKET**
- ❑ **"DPS" HIGH-PRESSURE UNITS, CONSISTING OF TWO SV "N" PUMPS CONNECTED IN SERIES**

APPLICATIONS

- Water transfer and circulation in the civil, industrial and agricultural sectors.
- Pressure boosting and water supply systems.
- Irrigation systems for agriculture and sporting facilities.
- Washing systems.
- Boiler feed.
- Water treatment and reverse osmosis plants.
- Fountains.
- Handling of moderately aggressive liquids.

SPECIFICATIONS

- **Delivery:** up to **72 m³/h**.
- **Head:** up to **247 m**.
- **Maximum** operating pressure: **16/25 bar**, depending on model.
- **Continuous duty.**
- **Temperature of pumped liquid: -20°C to +120°C.**
- Versions:
 - Single-phase** 220-240 V 50 Hz (up to 2.2 kW).
 - Three-phase** 220-240/380-415 V 50 Hz up to 3 kW (included), and 380-415/660 or 690 V for higher power (up to 22 kW).
- Class **F insulation**.



- **IP55 protection.**
- Threaded, round or oval **counterflanges** made of zinc-plated steel are **standard supply**.
- **Version with HYDROVAR frequency converter (variable speed) is available on request.**
- Versions with 4-pole motor are available on request.

AVAILABLE VERSIONS

VERSIONS	SV 2	SV 4	SV 8	SV 16	SV 30	SV 60
In-line ports with oval flanges	X	X	X			
In-line ports with round flanges	X	X	X	X	X	X
Overlying ports with position adjustment	X	X	X			
AISI 316 stainless steel liquid end	X	X	X	X	X	X
4-pole version	X	X	X	X	X	X
Horizontal version on brackets	X	X	X	X	X	X
With connectors for Victaulic coupling	X	X	X	X		

IDENTIFICATION CODE

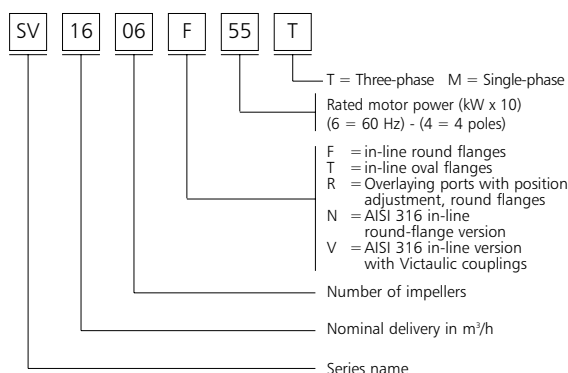

SV SERIES HYDRAULIC PERFORMANCE TABLE AT 2900 rpm 2 POLES

PUMP TYPE	POWER		Q = DELIVERY																			
			H = TOTAL HEAD METERS COLUMN OF WATER																			
			l/min	0	20	30	40	50	60	80	100	120	150	200	233	300	350	400	500	600	800	1000
		m ³ /h	0	1,2	1,8	2,4	3	3,6	4,8	6	7,2	9	12	14	18	21	24	30	36	48	60	72
		kW	HP																			
SV202F03	0,37	0,5	21,5	18,5	17	15	13	10,5														
SV203F03	0,37	0,5	32	28	25,5	23	19,5	15,5														
SV204F05	0,55	0,75	42,5	37,5	34	30,5	26	20,5														
SV205F07	0,75	1	53,5	47	42,5	38	32	26														
SV206F07	0,75	1	64	56	51	45,5	38,5	31														
SV207F11	1,1	1,5	75	65,5	60	53	45	36,5														
SV208F11	1,1	1,5	85,5	75	68	61	51,5	41,5														
SV209F11	1,1	1,5	96	84	76,5	68,5	58	46,5														
SV211F15	1,5	2	117	103	94	84	71	57														
SV212F15	1,5	2	128	112	102	91	77	62														
SV214F22	2,2	3	150	131	119	106	90	73														
SV216F22	2,2	3	171	150	136	122	103	83														
SV218F22	2,2	3	192	168	153	137	116	93														
SV220F30	3	4	214	187	170	152	129	104														
SV222F30	3	4	235	206	187	167	142	114														
SV224F30	3	4	256	224	205	182	155	125														
SV402F03	0,37	0,5	20			17	16	15	13	10,5	7,5											
SV403F05	0,55	0,75	30			25,5	24	23	19,5	16	11											
SV404F07	0,75	1	40			34	32	30,5	26	21	15											
SV405F11	1,1	1,5	50			42,5	40	38	32,5	26	18,5											
SV406F11	1,1	1,5	60			51	48	45,5	39	31,5	22											
SV407F11	1,1	1,5	70			59,5	56	53	46	37	26											
SV408F15	1,5	2	80			68	65	61	52,5	42	29,5											
SV409F15	1,5	2	90			76,5	73	68,5	59	47	33,5											
SV411F22	2,2	3	110			93,5	89	83,5	72	58	41											
SV413F22	2,2	3	130			111	105	99	85	68	48											
SV414F30	3	4	140			119	113	106	92	73,5	52											
SV416F30	3	4	160			136	129	122	105	84	59,5											
SV418F30	3	4	180			153	145	137	118	94,5	67											
SV420F40	4	5,5	200			170	161	152	131	105	74											
SV422F40	4	5,5	220			187	178	167	144	116	81,5											
SV424F40	4	5,5	240			204	194	182	157	126	89											
SV802F11	1,1	1,5	27						25,5	24,8	24	22	17,2	13,2								
SV803F15	1,5	2	41						38,5	37	36	33	25,8	20								
SV804F22	2,2	3	55						51	50	47,5	44	34,5	26,5								
SV805F22	2,2	3	68						64	62	60	55	43	33								
SV806F30	3	4	82						77	74,5	71	66	52	40								
SV808F40	4	5,5	110						103	99	95	87,5	69	53								
SV809F40	4	5,5	123						116	112	107	97,5	78	60								
SV811F55	5,5	7,5	150						141	137	130	119	95	73								
SV812F55	5,5	7,5	164						154	149	142	130	103	80								
SV814F75	7,5	10	192						180	174	166	152	120	93								
SV816F75	7,5	10	220						205	199	190	174	138	106								
SV1602F22	2,2	3	95								33,5	32,5	31	29,5	25	20	14,3					
SV1603F30	3	4	52								50	49	46	44	37,5	30,2	21,5					
SV1604F40	4	5,5	69								66,5	65	62	59	50	40,3	28,6					
SV1605F55	5,5	7,5	86								83	81	77	73	62	50	35,8					
SV1606F55	5,5	7,5	104								100	98	92	88	75	60,5	43					
SV1607F75	7,5	10	121								116	114	108	103	87	70,5	50					
SV1608F75	7,5	10	138								133	130	123	117	100	81	57					
SV1610F110	11	15	173								166	163	154	147	125	101	72					
SV1612F110	11	15	207								199	195	185	176	150	121	86					
SV1614F150	15	20	242								232	228	215	205	175	141	100					
SV1615F150	15	20	260								249	244	231	220	187	151	108					
SV3002F40	4	5,5	42											39	37	35	32,5	26,5	19			
SV3003F55	5,5	7,5	63											58	55	53	48	40	29			
SV3004F75	7,5	10	83											78	74	70	65	53	38			
SV3005F110	11	15	104											97	92	88	81	66	48			
SV3006F110	11	15	125											117	110	105	97	79	58			
SV3007F150	15	20	145											136	129	123	113	92	67			
SV3008F150	15	20	166											155	147	140	130	106	77			
SV3009F150	15	20	187											175	166	158	146	119	86			
SV3010F185	18,5	25	207											194	184	175	162	132	96			
SV3011F185	18,5	25	229											214	202	193	178	145	106			
SV3012F220	22	30	250											233	221	210	194	158	115			
SV6002F55	5,5	7,5	37													33	32	30	25	19	12	
SV6003F75	7,5	10	55													51	48	45	38	28	17	
SV6004F110	11	15	74													67	63	60	51	38	23	
SV6005F150	15	20	93													84	80	75	63	48	28	
SV6006F150	15	20	111													102	96	90	76	58	35	
SV6007F185	18,5	25	130													118	112	105	88	67	40	
SV6008F220	22	30	148													135	128	120	102	77	46	

Performances in compliance with ISO 9906 – Annex A

SV

SV2 SERIES (~ 2900 rpm)

MAIN CHARACTERISTICS

Working delivery 1.2 to 4.2 m³/h.

Maximum operating pressure, including water hammer on suction side:

- Pumps with oval flanges 16 bar.
- Pumps with round flanges 25 bar.

AVAILABLE VERSIONS

- "F" : In-line ports, round flanges from SV202 to SV224.
- "T" : In-line ports, oval flanges from SV202 to SV214.
- "R" : Overlying ports, round flanges from SV204 to SV224.
- "N" : In-line ports, round flanges made of AISI 316 from SV202 to SV224.

TABLE OF MATERIALS

PART	"F" "R" "T" MATERIALS	"N" MATERIALS
Impeller	AISI 316 L	
Diffuser and upper spacer	AISI 304	AISI 316 L
Shaft	AISI 304	AISI 316
Outer sleeve	AISI 304	AISI 316 L
Pump body	AISI 304	AISI 316 L
Shaft sleeve	TUNGSTEN CARBIDE	
Bushing	CERAMIC	
Mechanical seal	TUNGSTEN CARBIDE/CARBON/EPDM	
Elastomers	EPDM	
Fill/drain plugs	AISI 316	
Adapter	250 CAST IRON	
Coupling	ALUMINIUM	
Coupling protection	AISI 304	
Seal holding protection	AISI 304	AISI 316 L
Base mount	ALUMINIUM	

ELECTRICAL SPECIFICATIONS

PUMP TYPE	MOTOR POWER		INPUT CURRENT In Amp.					CAPACITOR		Is/In	
			THREE-PHASE			SINGLE-PHASE	μF	V	THREE-PHASE 230 V 400 V	SINGLE-PHASE 230 V	
			Δ	Y	Δ						220-240V
SV202F03T	0,37	71R	71R	2,30	1,33	-	2,64-2,72	14	450	4,23	3,08
SV203F03T	0,37	71R	71R	2,30	1,33	-	2,64-2,72	14	450	4,23	3,08
SV204F05T	0,55	71	71	2,48	1,43	-	3,89-4,05	16	450	5,95	3,34
SV205F07T	0,75	80R	80R	3,50	2,02	-	5,22-4,97	20	450	5,81	3,55
SV206F07T	0,75	80R	80R	3,50	2,02	-	5,22-4,97	20	450	5,81	3,55
SV207F11T	1,1	80	80	4,52	2,61	-	7,07-6,81	30	450	6,78	3,80
SV208F11T	1,1	80	80	4,52	2,61	-	7,07-6,81	30	450	6,78	3,80
SV209F11T	1,1	80	80	4,52	2,61	-	7,07-6,81	30	450	6,78	3,80
SV211F15T	1,5	90R	90R	5,98	3,45	-	9,32-8,63	40	450	7,04	3,45
SV212F15T	1,5	90R	90R	5,98	3,45	-	9,32-8,63	40	450	7,04	3,45
SV214F22T	2,2	90R	90	8,71	5,03	-	13,3-12,6	50	450	7,32	3,45
SV216F22T	2,2	90R	90	8,71	5,03	-	13,3-12,6	50	450	7,32	3,45
SV218F22T	2,2	90R	90	8,71	5,03	-	13,3-12,6	50	450	7,32	3,45
SV220F30T	3	100R	-	10,8	6,22	-	-	-	-	6,81	-
SV222F30T	3	100R	-	10,8	6,22	-	-	-	-	6,81	-
SV224F30T	3	100R	-	10,8	6,22	-	-	-	-	6,81	-

* R = Reduced size of motor casing as compared to shaft extension and flange.

DIMENSIONS AND WEIGHTS

PUMP TYPE	DNA DNM	DIMENSIONS IN mm														WEIGHT (kg)		
		L1	L2 SINGLE-THREE-PHASE	L3	L4	L5	L6	L7	M SINGLE-THREE-PHASE	D1 SINGLE-THREE-PHASE	D2	H	A	B	PUMP	ELECTRIC PUMP		
SV202F03T	Rp 1"	285	209	209	-	260	260	260	111	111	120	120	105	93	50	20	9,5	17,5
SV203F03T	Rp 1"	310	209	209	-	285	285	285	111	111	120	120	105	93	50	20	10	18
SV204F05T	Rp 1"	335	231	231	335	200	310	310	121	121	140	140	105	93	50	20	10,5	19
SV205F07T	Rp 1"	370	226	226	370	225	345	345	121	121	140	140	120	103	50	20	11,5	21
SV206F07T	Rp 1"	395	226	226	395	250	370	370	121	121	140	140	120	103	50	20	12	22
SV207F11T	Rp 1"	420	263	263	420	275	395	395	137	129	155	155	120	103	50	20	12,5	23
SV208F11T	Rp 1"	445	263	263	445	300	420	420	137	129	155	155	120	103	50	20	13	23
SV209F11T	Rp 1"	470	263	263	470	325	445	445	137	129	155	155	120	103	50	20	13,5	24
SV211F15T	Rp 1"	530	263	263	530	375	505	505	137	129	155	155	140	113	50	20	15	31
SV212F15T	Rp 1"	555	263	263	555	400	530	530	137	129	155	155	140	113	50	20	15,5	31
SV214F22T	Rp 1"	605	281	263	605	450	580	580	121	129	176	155	140	113	50	20	16,5	33
SV216F22T	Rp 1"	655	281	263	655	500	630	655	121	129	176	155	140	113	75	25	17,5	34
SV218F22T	Rp 1"	705	281	263	705	550	680	705	121	129	176	155	140	113	75	25	18,5	35
SV220F30T	Rp 1"	765	-	303	765	600	740	765	-	121	-	176	160	123	75	25	20	42
SV222F30T	Rp 1"	815	-	303	815	650	790	815	-	121	-	176	160	123	75	25	21	43
SV224F30T	Rp 1"	865	-	303	865	700	840	865	-	121	-	176	160	123	75	25	22	44

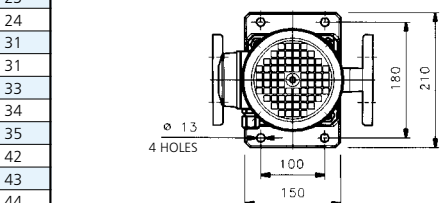
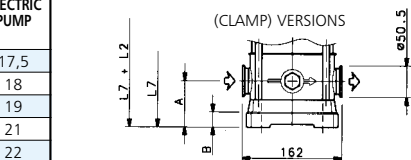
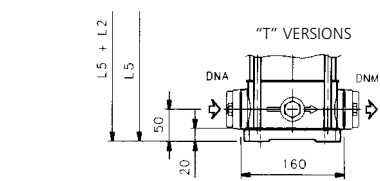
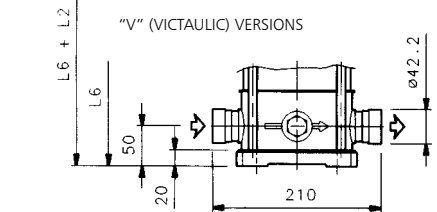
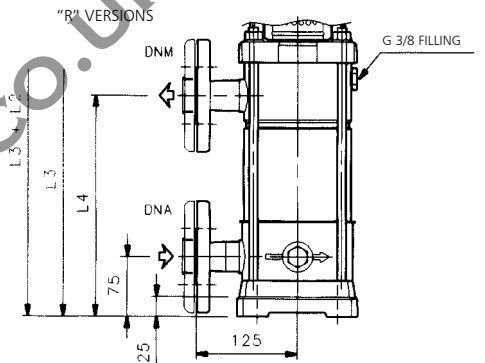
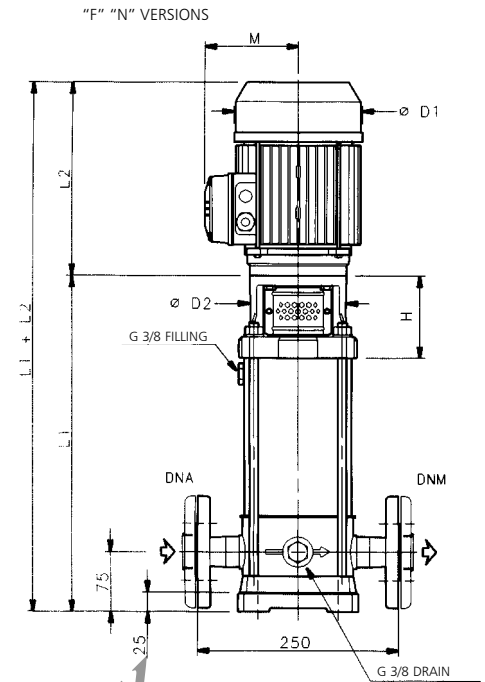

SV2 SERIES OPERATING CHARACTERISTICS AT 2900 rpm 50 Hz

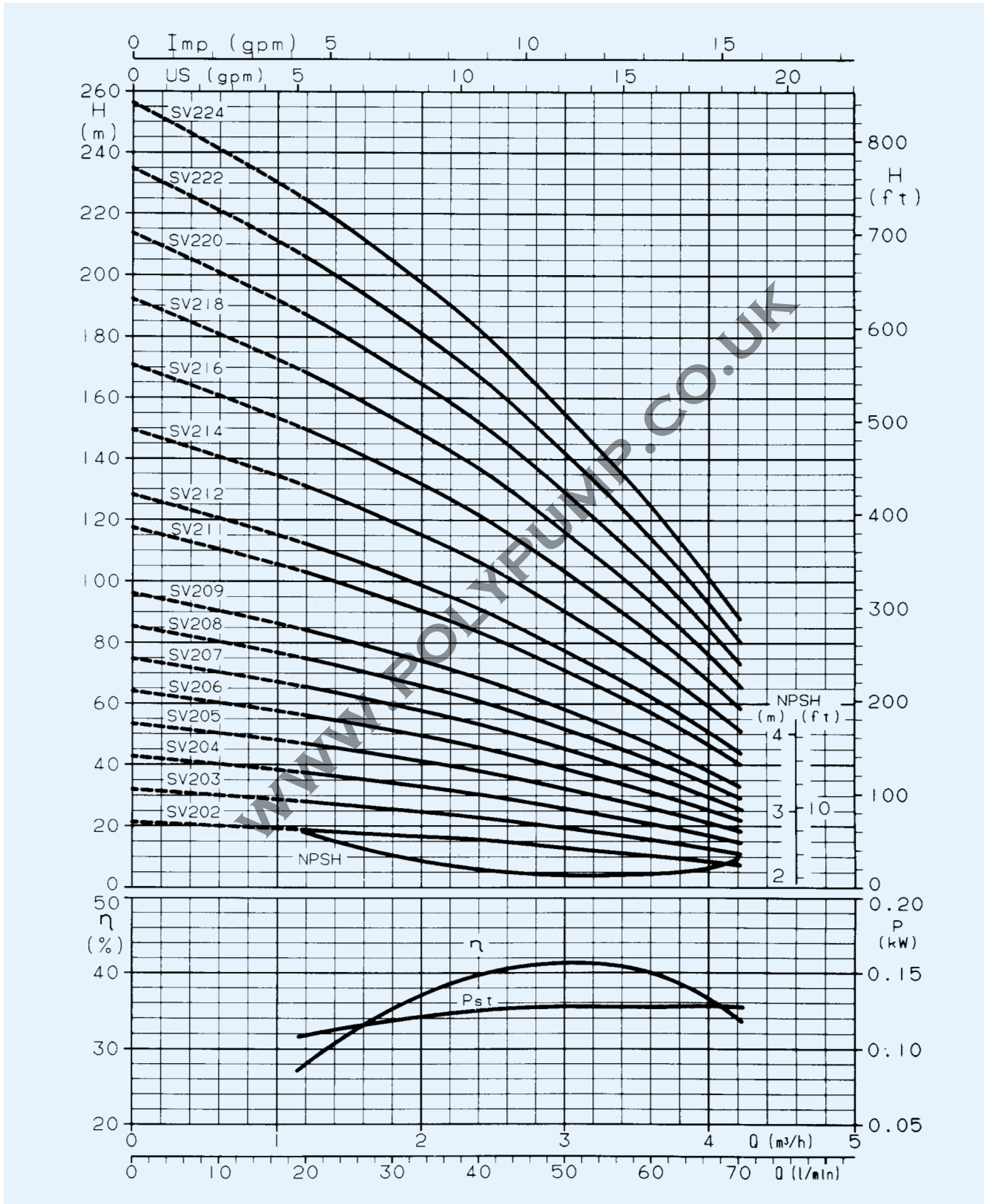

These performances are valid for liquids with density $\rho = 1.0 \text{ kg/dm}^3$ and kinematic viscosity $\nu = 1 \text{ mm}^2/\text{sec}$.



SV4 SERIES (~ 2900 rpm)

MAIN CHARACTERISTICS

Working delivery 2.4 to 8 m³/h.

Maximum operating pressure, including water hammer on suction side:

- Pumps with oval flanges 16 bar.
- Pumps with round flanges 25 bar.

AVAILABLE VERSIONS

- "F" : In-line ports, round flanges from SV402 to SV424.
- "T" : In-line ports, oval flanges from SV402 to SV414.
- "R" : Overlying ports, round flanges from SV405 to SV424.
- "N" : In-line ports, round flanges made of AISI 316 from SV402 to SV424.

TABLE OF MATERIALS

PART	"F" "R" "T" MATERIALS	"N" MATERIALS
Impeller	AISI 316 L	
Diffuser and upper spacer	AISI 304	AISI 316 L
Shaft	AISI 304	AISI 316
Outer sleeve	AISI 304	AISI 316 L
Pump body	AISI 304	AISI 316 L
Shaft sleeve	TUNGSTEN CARBIDE	
Bushing	CERAMIC	
Mechanical seal	TUNGSTEN CARBIDE/CARBON/EPDM	
Elastomers	EPDM	
Fill/drain plugs	AISI 316	
Adapter	250 CAST IRON	
Coupling	ALUMINIUM	
Coupling protection	AISI 304	
Seal holding disk	AISI 304	AISI 316 L
Base mount	ALUMINIUM	

ELECTRICAL SPECIFICATIONS

PUMP TYPE	MOTOR POWER			INPUT CURRENT				CAPACITOR		Is/In	
				In Amp.			SINGLE-PHASE				
				THREE-PHASE	THREE-PHASE	THREE-PHASE					
	kW	SIZE* T	M	Δ	Y	Δ	220-240V	230 V	400 V	230 V	230 V
SV402F03T	0,37	71R	71R	2,30	1,33	-	2,64-2,72	14	450	4,23	3,08
SV403F05T	0,55	71	71	2,48	1,43	-	3,89-4,05	16	450	5,95	3,34
SV404F07T	0,75	80R	80R	3,50	2,02	-	5,22-4,97	20	450	5,81	3,55
SV405F11T	1,1	80	80	4,52	2,61	-	7,07-6,81	30	450	6,78	3,80
SV406F11T	1,1	80	80	4,52	2,61	-	7,07-6,81	30	450	6,78	3,80
SV407F11T	1,1	80	80	4,52	2,61	-	7,07-6,81	30	450	6,78	3,80
SV408F15T	1,5	90R	90R	5,98	3,45	-	9,32-8,63	40	450	7,04	3,45
SV409F15T	1,5	90R	90R	5,98	3,45	-	9,32-8,63	40	450	7,04	3,45
SV411F22T	2,2	90R	90	8,71	5,03	-	13,3-12,6	50	450	7,32	3,45
SV413F22T	2,2	90R	90	8,71	5,03	-	13,3-12,6	50	450	7,32	3,45
SV414F30T	3	100R	-	10,8	6,22	-	-	-	-	6,81	-
SV416F30T	3	100R	-	10,8	6,22	-	-	-	-	6,81	-
SV418F30T	3	100R	-	10,8	6,22	-	-	-	-	6,81	-
SV420F40T	4	112R	-	-	-	8,14	-	-	-	7,86	-
SV422F40T	4	112R	-	-	-	8,14	-	-	-	7,86	-
SV424F40T	4	112R	-	-	-	8,14	-	-	-	7,86	-

* R = Reduced size of motor casing as compared to shaft extension and flange.

DIMENSIONS AND WEIGHTS

PUMP TYPE	DNA DNM	DIMENSIONS IN mm														WEIGHT (kg)			
		L1	L2 SINGLE- PHASE	L3	L4	L5	L6	L7	M SINGLE- PHASE	D1 THREE- PHASE	D2	H	A	B	PUMP	ELECTRIC PUMP			
																	THREE- PHASE	THREE- PHASE	THREE- PHASE
SV402F03T	Rp 1 1/4	285	209	209	-	-	260	260	260	111	111	120	120	105	93	50	20	9,5	17,5
SV403F05T	Rp 1 1/4	310	231	231	-	-	285	285	285	121	121	140	140	105	93	50	20	10	18,5
SV404F07T	Rp 1 1/4	345	226	226	-	-	320	320	320	121	121	140	140	120	103	50	20	11	21
SV405F11T	Rp 1 1/4	370	263	263	370	225	345	345	345	137	129	155	155	120	103	50	20	11,5	22
SV406F11T	Rp 1 1/4	395	263	263	395	250	370	370	370	137	129	155	155	120	103	50	20	12	22
SV407F11T	Rp 1 1/4	420	263	263	420	275	395	395	395	137	129	155	155	120	103	50	20	12,5	23
SV408F15T	Rp 1 1/4	455	263	263	455	300	430	430	430	137	129	155	155	140	113	50	20	13,5	29
SV409F15T	Rp 1 1/4	480	263	263	480	325	455	455	455	137	129	155	155	140	113	50	20	14	30
SV411F22T	Rp 1 1/4	530	281	263	530	375	505	505	505	121	129	176	155	140	113	50	20	15	32
SV413F22T	Rp 1 1/4	580	281	263	580	425	555	555	555	121	129	176	155	140	113	50	20	16	33
SV414F30T	Rp 1 1/4	615	-	303	615	450	590	590	590	-	121	-	176	160	123	50	20	17	39
SV416F30T	Rp 1 1/4	665	-	303	665	500	-	640	665	-	121	-	176	160	123	75	25	18	40
SV418F30T	Rp 1 1/4	715	-	303	715	550	-	690	715	-	121	-	176	160	123	75	25	19	41
SV420F40T	Rp 1 1/4	765	-	307	765	600	-	740	765	-	133	-	193	160	123	75	25	20	58
SV422F40T	Rp 1 1/4	815	-	307	815	650	-	790	815	-	133	-	193	160	123	75	25	21	59
SV424F40T	Rp 1 1/4	865	-	307	865	700	-	840	865	-	133	-	193	160	123	75	25	22	60

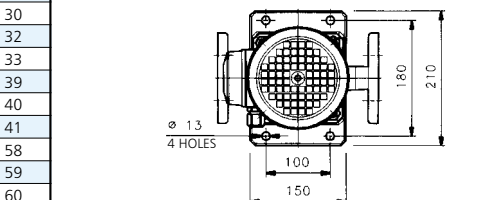
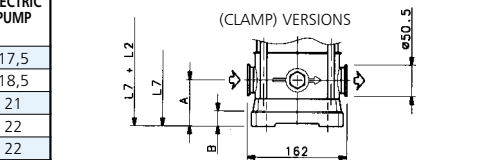
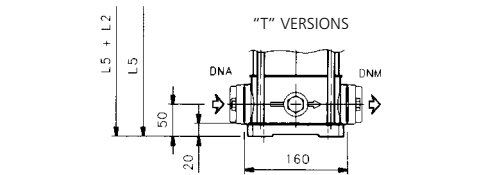
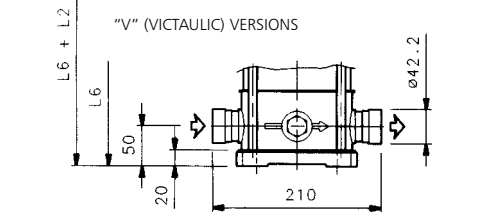
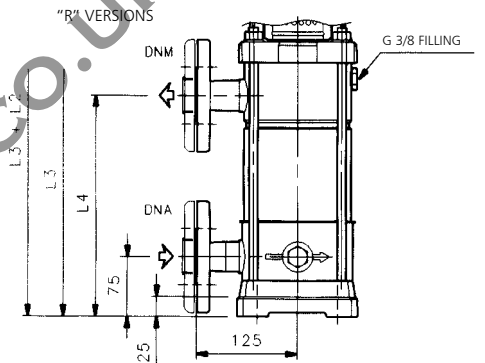
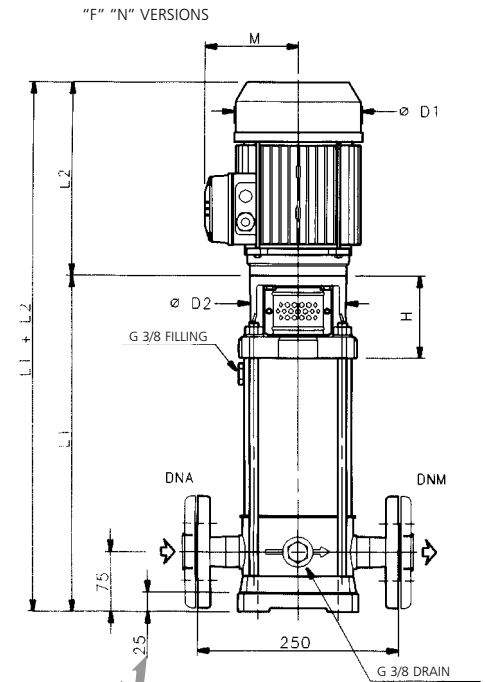

SV4 SERIES OPERATING CHARACTERISTICS AT 2900 rpm 50 Hz

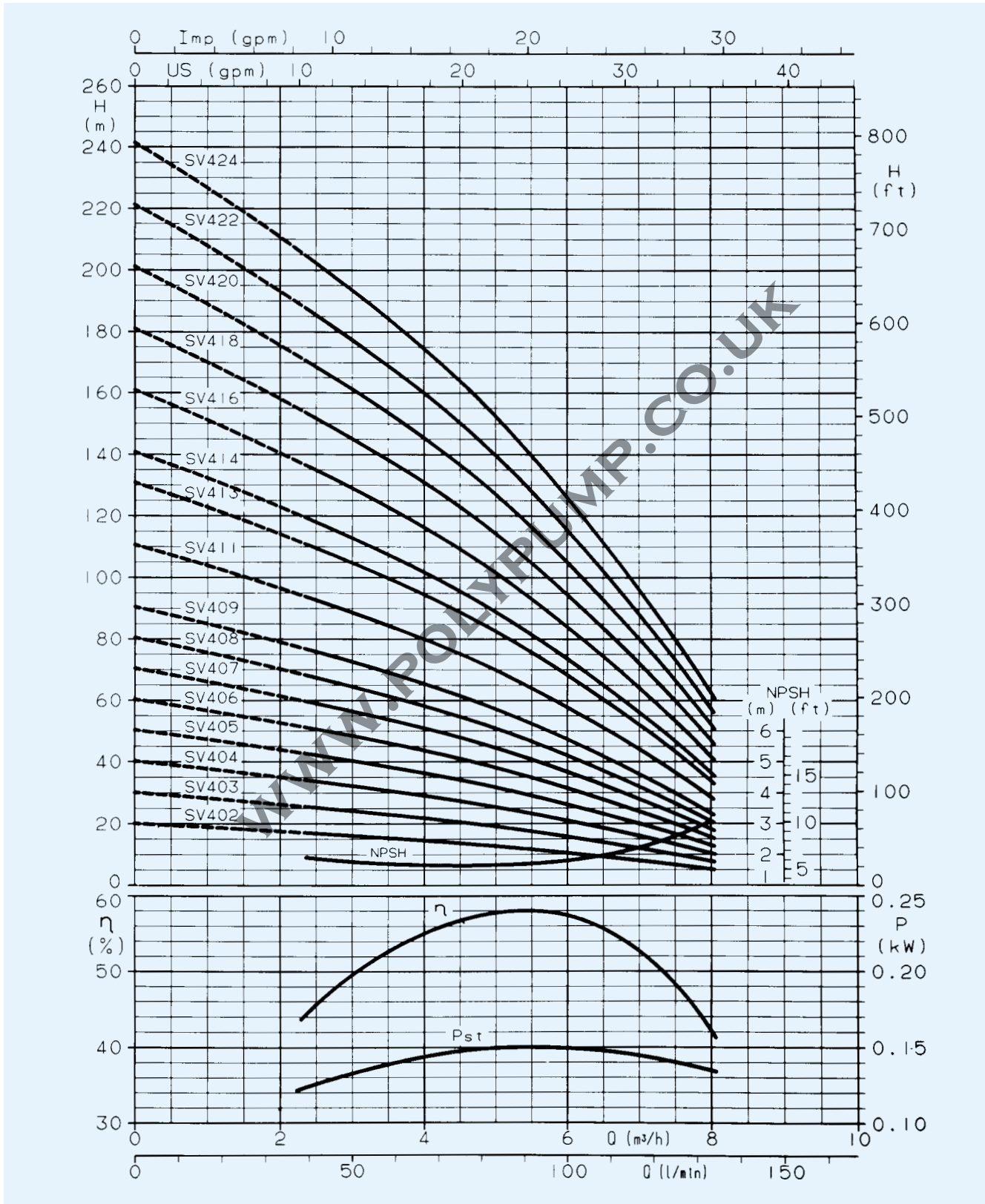

These performances are valid for liquids with density $\rho = 1.0 \text{ kg/dm}^3$ and kinematic viscosity $\gamma = 1 \text{ mm}^2/\text{sec}$.



SV8 SERIES (~ 2900 rpm)

MAIN CHARACTERISTICS

Working delivery 6 to 14 m³/h

Maximum operating pressure, including water hammer on suction side:

- Pumps with oval flanges 16 bar.
- Pumps with round flanges 25 bar.

AVAILABLE VERSIONS

- "F" : In-line ports, round flanges from SV802 to SV816.
- "T" : In-line ports, oval flanges from SV802 to SV811.
- "R" : Overlaying ports, round flanges from SV803 to SV816.
- "N" : In-line ports, round flanges made of AISI 316 from SV802 to SV816.

TABLE OF MATERIALS

PART	"F" "R" "T" MATERIALS	"N" MATERIALS
Impeller	AIS I 316 L	
Diffuser and upper spacer	AISI 304	AISI 316 L
Shaft	AISI 304	AISI 316
Outer sleeve	AISI 304	AISI 316 L
Pump body	AISI 304	AISI 316 L
Shaft sleeve	TUNGSTEN CARBIDE	
Bushing	CERAMIC	
Mechanical seal	TUNGSTEN CARBIDE/CARBON/EPDM	
Elastomers	EPDM	
Fill/drain plugs	AIS I 316	
Adapter	250 CAST IRON	
Coupling	ALUMINIUM UP TO 4 kW 200 CAST IRON FOR HIGHER POWER	
Coupling protection	AIS I 304	
Seal holding disk	AISI 304	AISI 316 L
Base mount	ALUMINIUM	

ELECTRICAL SPECIFICATIONS

PUMP TYPE	MOTOR POWER			INPUT CURRENT In Amp.						CAPACITOR		Is/In	
				THREE-PHASE			SINGLE-PHASE	μF	V	THREE-PHASE 230 V 400 V	SINGLE-PHASE 230 V		
				Δ	Y	Δ						220-240V	380-415V
SV802F11T	1,1	80	80	4,52	2,61	-	7,07-6,81	30	450	6,78	3,80		
SV803F15T	1,5	90R	90R	5,98	3,45	-	9,32-8,63	40	450	7,04	3,45		
SV804F22T	2,2	90R	90	8,71	5,03	-	13,3-12,6	50	450	7,32	3,45		
SV805F22T	2,2	90R	90	8,71	5,03	-	13,3-12,6	50	450	7,32	3,45		
SV806F30T	3	100R	-	10,8	6,22	-	-	-	-	6,81	-		
SV808F40T	4	112R	-	-	-	8,14	-	-	-	7,86	-		
SV809F40T	4	112R	-	-	-	8,14	-	-	-	7,86	-		
SV811F55T	5,5	132R	-	-	-	11,0	-	-	-	7,71	-		
SV812F55T	5,5	132R	-	-	-	11,0	-	-	-	7,71	-		
SV814F75T	7,5	132R	-	-	-	14,6	-	-	-	7,62	-		
SV816F75T	7,5	132R	-	-	-	14,6	-	-	-	7,62	-		

* R = Reduced size of motor casing as compared to shaft extension and flange.

DIMENSIONS AND WEIGHTS

PUMP TYPE	DNA DNM	DIMENSIONS IN mm														WEIGHT (kg)	
		L1	SINGLE-PHASE L2	THREE-PHASE L2	L3	L4	L5	L6	M SINGLE-PHASE	THREE-PHASE	D1 SINGLE-PHASE	THREE-PHASE	D2	H	PUMP	ELECTRIC PUMP	
SV802F11T	Rp 1 1/2	363	263	263	-	-	363	373	137	129	155	155	120	112	15	25	
SV803F15T	Rp 1 1/2	411	263	263	411	236	411	421	137	129	155	155	140	122	16	32	
SV804F22T	Rp 1 1/2	449	281	263	449	274	449	459	121	129	176	155	140	122	17	34	
SV805F22T	Rp 1 1/2	487	281	263	487	312	487	497	121	129	176	155	140	122	18	35	
SV806F30T	Rp 1 1/2	535	-	303	535	350	535	545	-	121	-	176	160	132	20	42	
SV808F40T	Rp 1 1/2	611	-	307	611	426	611	621	-	133	-	193	160	132	20	58	
SV809F40T	Rp 1 1/2	649	-	307	649	464	649	659	-	133	-	193	160	132	21	59	
SV811F55T	Rp 1 1/2	745	-	374	745	540	745	755	-	151	-	220	300	152	28	74	
SV812F55T	Rp 1 1/2	783	-	374	783	578	-	793	-	151	-	220	300	152	29	75	
SV814F75T	Rp 1 1/2	859	-	374	859	654	-	869	-	151	-	220	300	152	31	81	
SV816F75T	Rp 1 1/2	935	-	374	935	730	-	945	-	151	-	220	300	152	32	82	

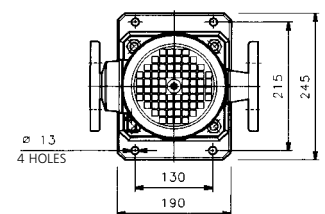
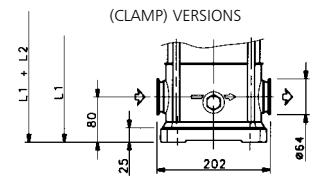
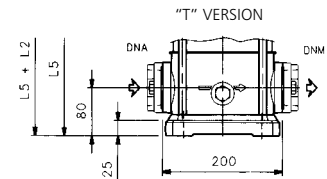
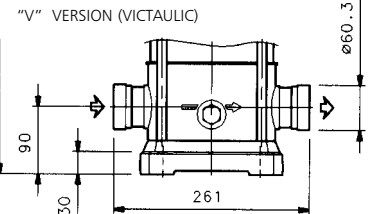
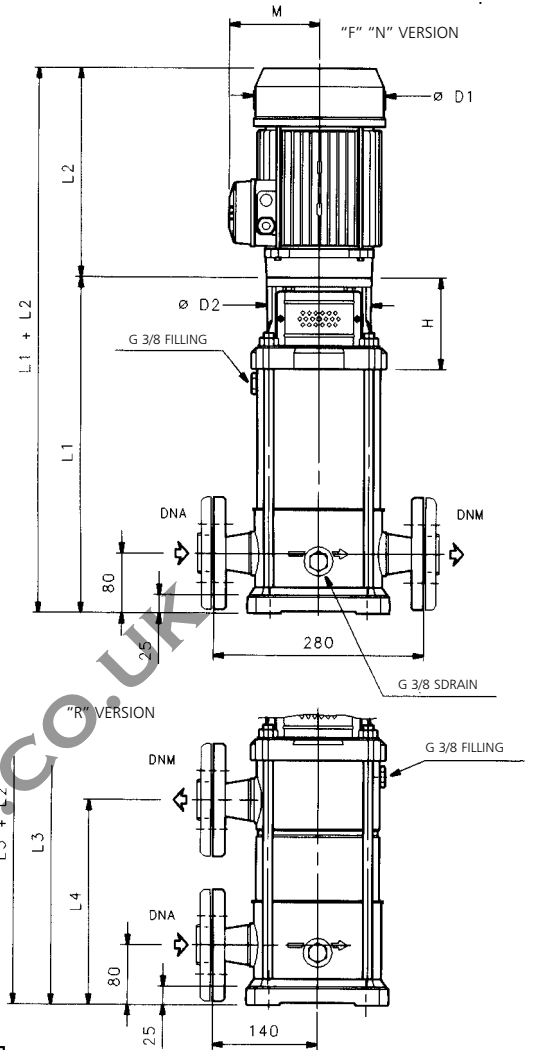

SV8 SERIES OPERATING CHARACTERISTICS AT 2900 rpm 50 Hz

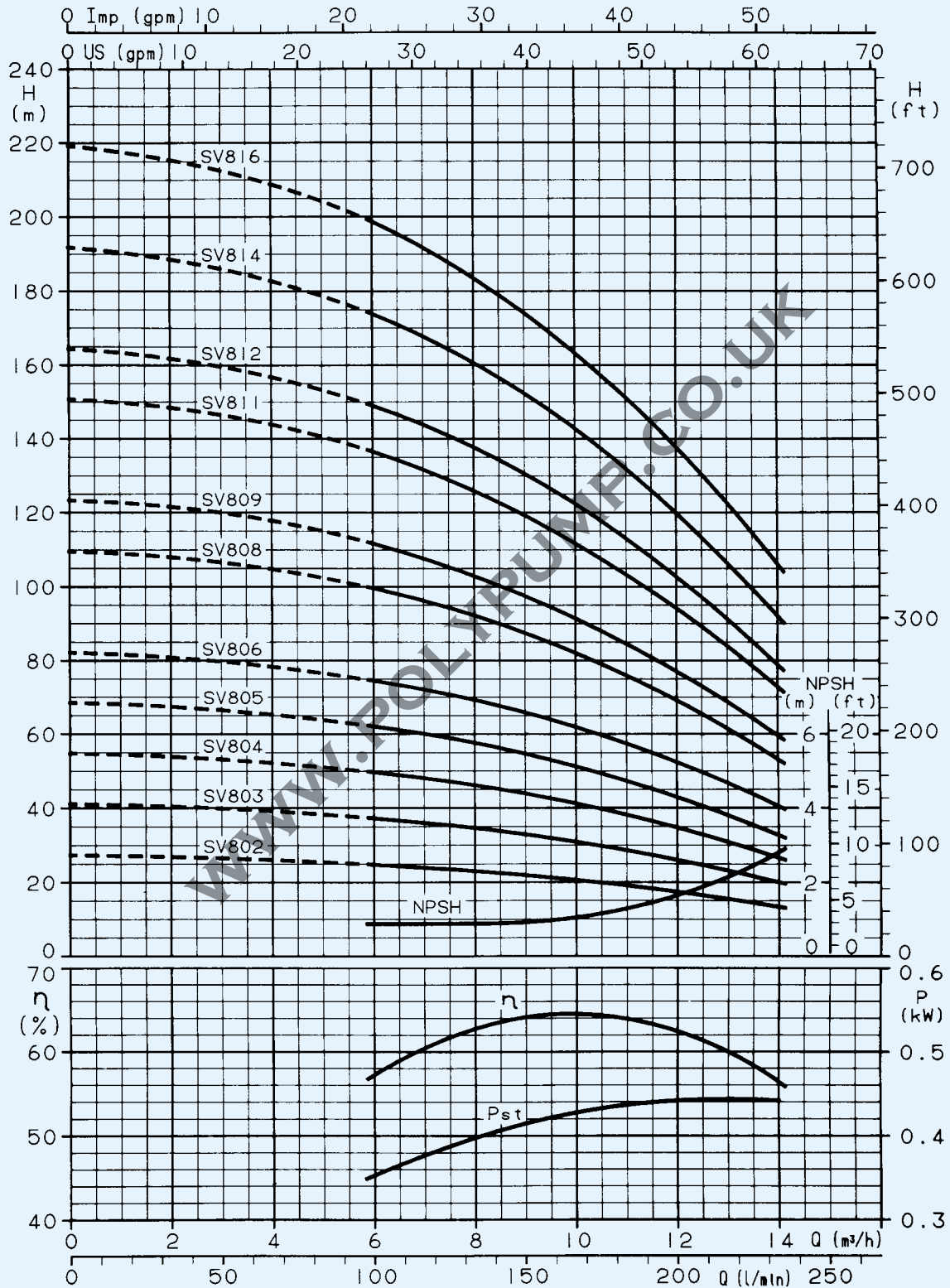

These performances are valid for liquids with density $\rho = 1.0 \text{ kg/dm}^3$ and kinematic viscosity $\nu = 1 \text{ mm}^2/\text{sec}$.



SV16 SERIES (~ 2900 rpm)

MAIN CHARACTERISTICS

Working delivery 8 to 24 m³/h.

Maximum operating pressure, including water hammer on suction side:

– Pumps with round flanges 25 bar.

AVAILABLE VERSIONS

– “F” : In-line ports, round flanges from SV1602 to SV1615.

– “N” : In-line ports, round flanges in AISI 316 from SV1602 to SV1615.

TABLE OF MATERIALS

PART	“F” MATERIALS	“N” MATERIALS
Impeller	AISI 316 L	
Diffuser and upper spacer	AISI 304	AISI 316 L
Shaft	AISI 304	AISI 316
Outer sleeve	AISI 304	AISI 316 L
Pump body	AISI 304	AISI 316 L
Shaft sleeve	TUNGSTEN CARBIDE	
Bushing	CERAMIC	
Mechanical seal	TUNGSTEN CARBIDE/CARBON/EPDM	
Elastomers	EPDM	
Fill/drain plugs	AISI 316	
Adapter	250 CAST IRON	
Coupling	Aluminium UP TO 4 kW 200 CAST IRON FOR HIGHER POWER	
Coupling protection	AISI 304	
Seal holding disk	AISI 304	AISI 316 L
Base mount	ALUMINIUM	

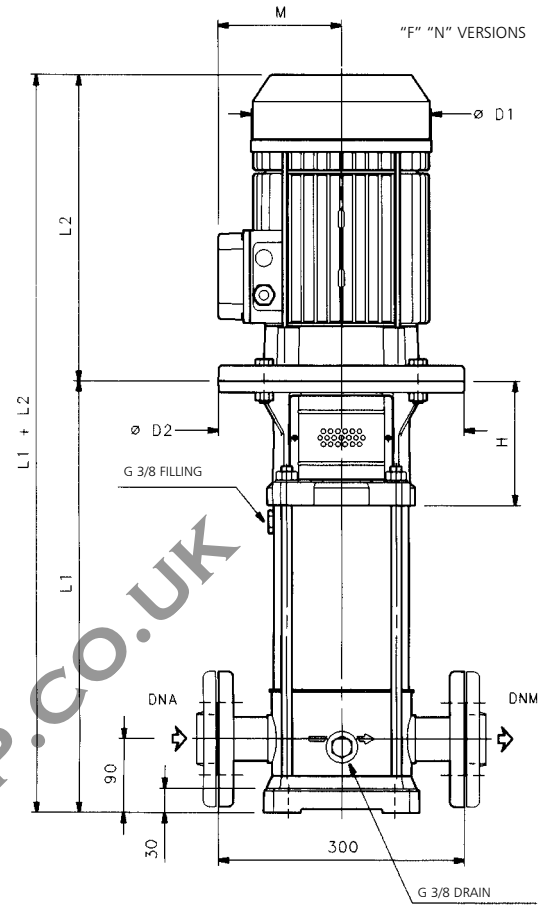

ELECTRICAL SPECIFICATIONS

PUMP TYPE	MOTOR POWER		INPUT CURRENT In Amp.					CAPACITOR		Is/In	
			THREE-PHASE			SINGLE-PHASE	μF	V	THREE-PHASE 230 V 400 V	SINGLE-PHASE 230 V	
			Δ	Y	Δ	220-240V					
SV1602F22T	2,2	90R	90	8,71	5,03	380-415V	220-240V	50	450	7,32	3,45
SV1603F30T	3	100R	–	10,8	6,22	–	–	–	–	6,81	–
SV1604F40T	4	112R	–	–	–	8,14	–	–	–	7,86	–
SV1605F55T	5,5	132R	–	–	–	11,0	–	–	–	7,71	–
SV1606F55T	5,5	132R	–	–	–	11,0	–	–	–	7,71	–
SV1607F75T	7,5	132R	–	–	–	14,6	–	–	–	7,62	–
SV1608F75T	7,5	132R	–	–	–	14,6	–	–	–	7,62	–
SV1610F110T	11	160R	–	–	–	21,2	–	–	–	8,75	–
SV1612F110T	11	160R	–	–	–	21,2	–	–	–	8,75	–
SV1614F150T	15	160	–	–	–	28,6	–	–	–	8,56	–
SV1615F150T	15	160	–	–	–	28,6	–	–	–	8,56	–

* R = Reduced size of motor casing as compared to shaft extension and flange.

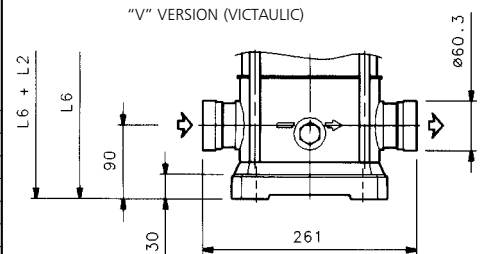

(CLAMP) VERSIONS

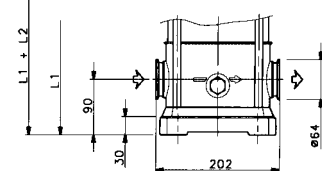

ELECTRICAL SPECIFICATIONS

PUMP TYPE	DNA DNM	DIMENSIONS IN mm												WEIGHT (kg)		
		L1	L2 SINGLE-PHASE	L2 THREE-PHASE	L3	L4	L5	L6	M SINGLE-PHASE	M THREE-PHASE	D1 SINGLE-PHASE	D1 THREE-PHASE	D2	H	PUMP	ELECTRIC PUMP
SV1602F22T	Rp 2"	383	281	263	–	–	–	383	121	129	176	155	140	122	15	32
SV1603F30T	Rp 2"	431	–	303	–	–	–	431	–	121	–	176	160	132	16	38
SV1604F40T	Rp 2"	469	–	307	–	–	–	469	–	133	–	193	160	132	17,5	55
SV1605F55T	Rp 2"	527	–	374	–	–	–	527	–	151	–	220	300	152	22	68
SV1606F55T	Rp 2"	565	–	374	–	–	–	565	–	151	–	220	300	152	23	69
SV1607F75T	Rp 2"	603	–	374	–	–	–	603	–	151	–	220	300	152	24	74
SV1608F75T	Rp 2"	641	–	374	–	–	–	–	–	151	–	220	300	152	25	75
SV1610F110T	Rp 2"	749	–	427	–	–	–	749	–	191	–	257	350	184	34	119
SV1612F110T	Rp 2"	825	–	427	–	–	–	825	–	191	–	257	350	184	36	121
SV1614F150T	Rp 2"	901	–	488	–	–	–	901	–	232	–	310	350	184	38	130
SV1615F150T	Rp 2"	939	–	488	–	–	–	939	–	232	–	310	350	184	39	131

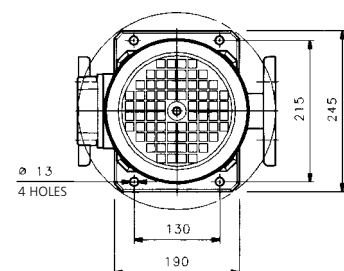

SV16 SERIES OPERATING CHARACTERISTICS AT 2900 rpm 50 Hz

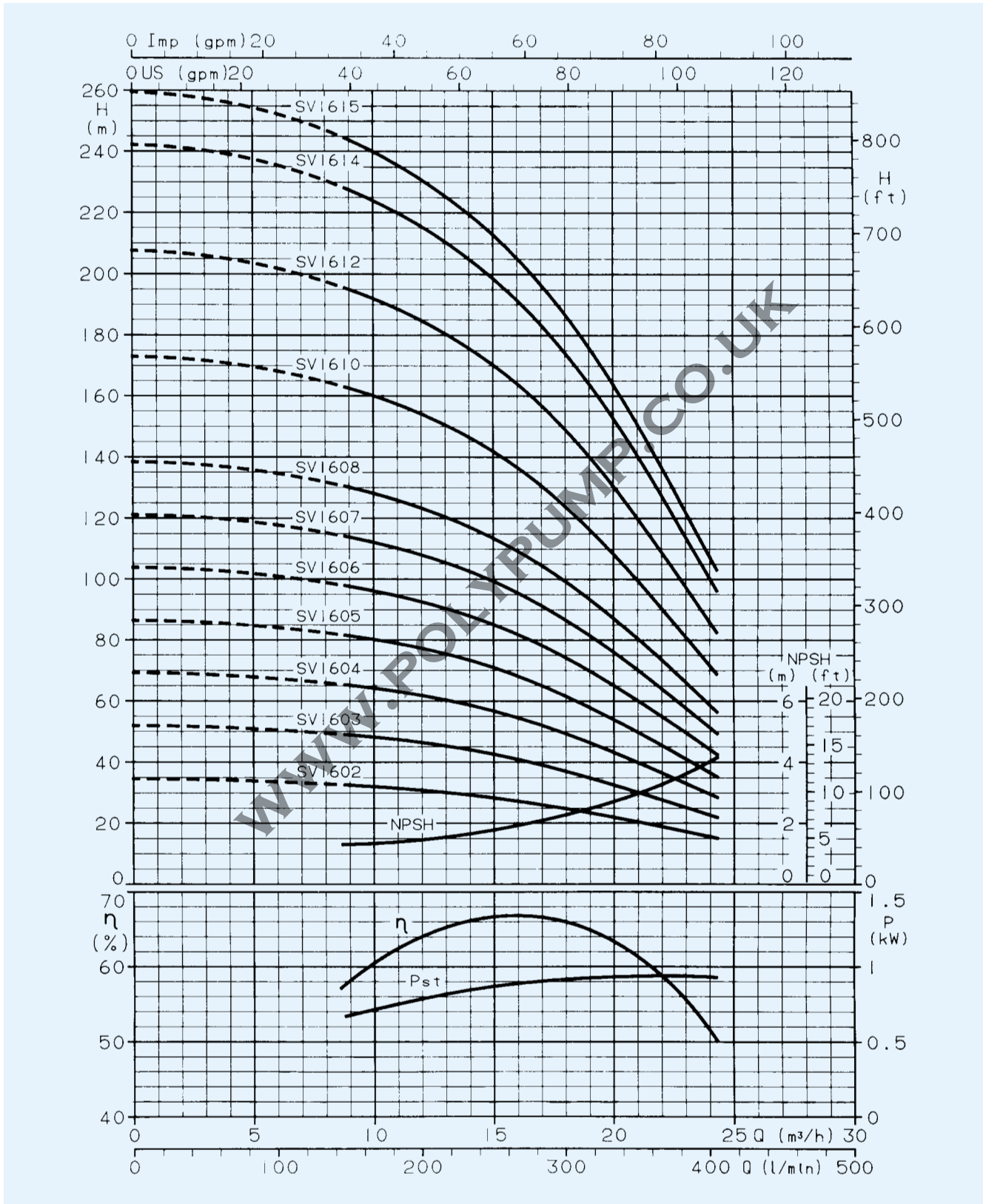

These performances are valid for liquids with density $\rho = 1.0 \text{ kg/dm}^3$ and kinematic viscosity $\gamma = 1 \text{ mm}^2/\text{sec}$.



SV30 SERIES (~ 2900 rpm)

MAIN CHARACTERISTICS

Working delivery 15 to 39 m³/h.

Maximum operating pressure, including water hammer on suction side:

- Up to SV3006 16 bar.
- From SV3007 to SV3012 25 bar.

AVAILABLE VERSIONS

- "F" : In-line ports, round flanges from SV3002 to SV3012.
- "N" : In-line ports, round flanges in AISI 316 from SV3002 to SV3012.

TABLE OF MATERIALS

PART	"F" MATERIALS	"N" MATERIALS
Impeller	AISI 316 L	
Diffuser and upper spacer	AISI 316 L	
Shaft	AISI 431	AISI 316
Outer sleeve	AISI 304	AISI 316 L
Pump body	250 CAST IRON	CF - 8M (AISI 316 L)
Shaft sleeve	TUNGSTEN CARBIDE	
Bushing	CERAMIC	
Mechanical seal	SILICON/CARBIDE/CARBON/EPDM	
Elastomers	EPDM	
Fill/drain plugs	NICKEL PLATED BRASS	AISI 316
Spider	250 CAST IRON	
Coupling	200 CAST IRON	
Coupling protection	AISI 304	
Seal holding disk	-	AISI 316 L

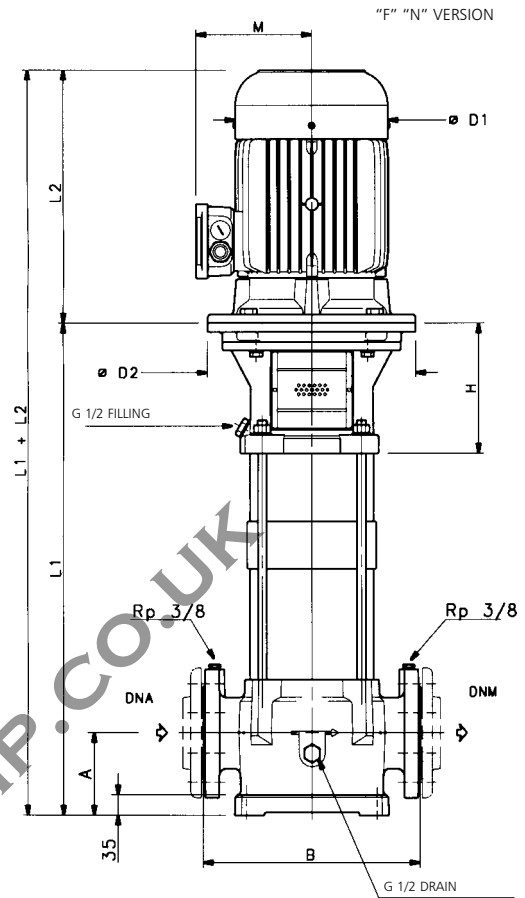

ELECTRICAL SPECIFICATIONS

PUMP TYPE	MOTOR POWER		INPUT CURRENT In Amp.			Is/In
			THREE-PHASE			
			Δ 220-240 V	Y 380-415 V	Δ 380-415 V	
SV3002F40T	4	112R	-	-	8,14	7,86
SV3003F55T	5,5	132R	-	-	11,0	7,71
SV3004F75T	7,5	132R	-	-	14,6	7,62
SV3005F110T	11	160R	-	-	21,2	8,75
SV3006F110T	11	160R	-	-	21,2	8,75
SV3007F150T	15	160	-	-	28,6	8,56
SV3008F150T	15	160	-	-	28,6	8,56
SV3009F150T	15	160	-	-	28,6	8,56
SV3010F185T	18,5	160	-	-	34,2	8,80
SV3011F185T	18,5	160	-	-	34,2	8,80
SV3012F220T	22	180R	-	-	40,3	8,61

* R = Reduced size of motor casing as compared to shaft extension and flange.

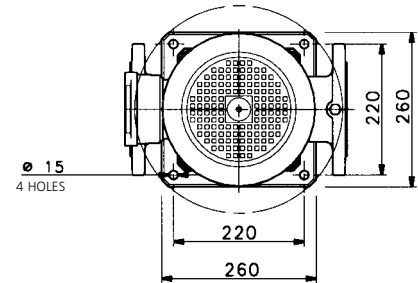

DIMENSIONS AND WEIGHTS

PUMP TYPE	DNA DNM	DIMENSIONS IN mm								WEIGHT (kg)	
		L1	L2	A	B	M	D1	D2	H	PUMP	ELECTRIC PUMP
SV3002F40T	65	588	307	105	320	133	193	160	170	48	78
SV3003F55T	65	680	374	105	320	151	220	300	190	56	102
SV3004F75T	65	752	374	105	320	151	220	300	190	59	109
SV3005F110T	65	856	427	105	320	191	257	350	222	70	155
SV3006F110T	65	1120	427	105	320	191	257	350	222	83	168
SV3007F150T	65	1192	488	105	320	232	310	350	222	86	178
SV3008F150T	65	1264	488	105	320	232	310	350	222	89	181
SV3009F150T	65	1336	488	105	320	232	310	350	222	93	185
SV3010F185T	65	1408	532	105	320	232	310	350	222	96	195
SV3011F185T	65	1480	532	105	320	232	310	350	222	99	198
SV3012F220T	65	1552	532	105	320	232	310	350	222	102	216

SV30 SERIES OPERATING CHARACTERISTICS AT 2900 rpm 50 Hz

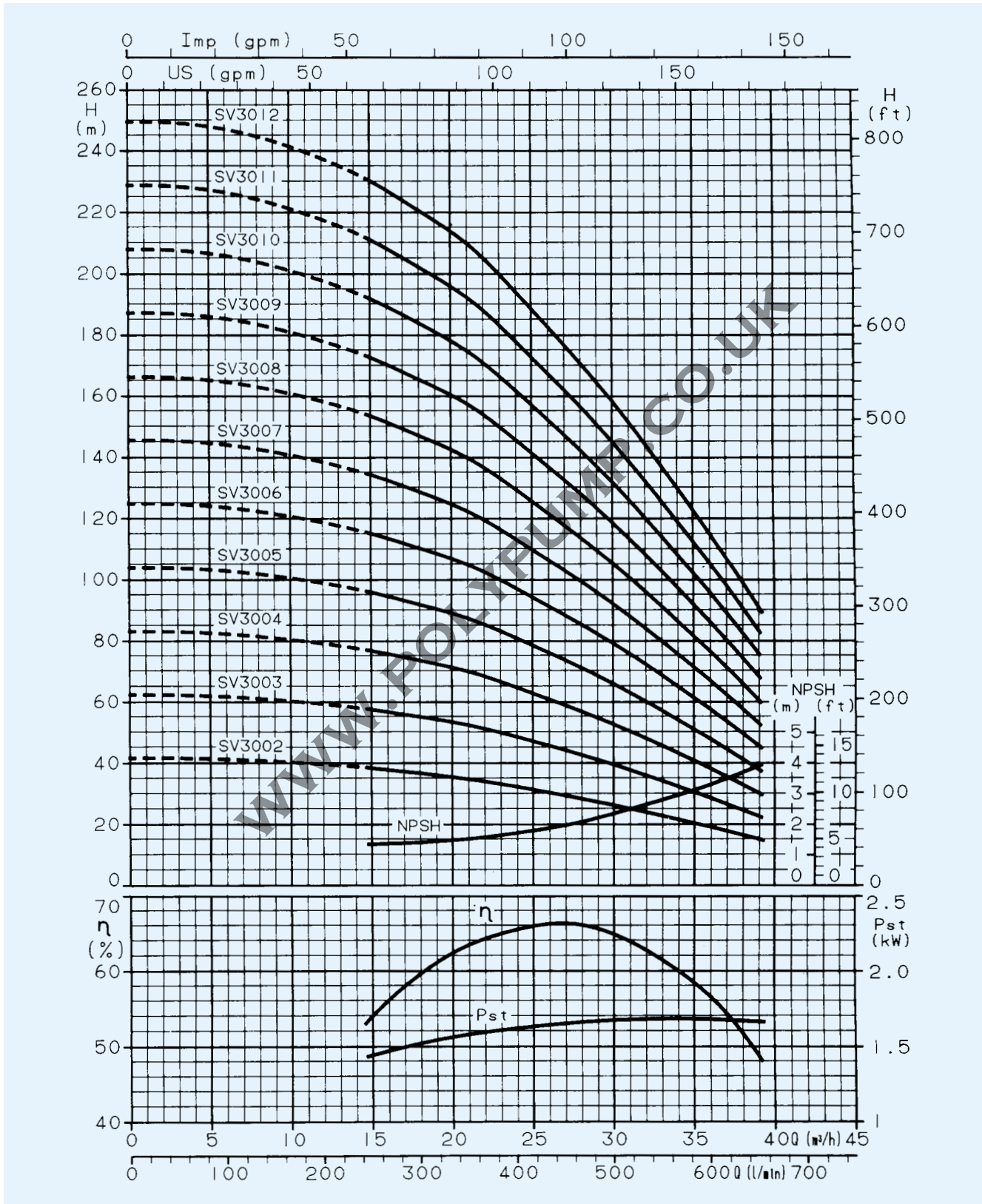

These performances are valid for liquids with density $\rho = 1.0 \text{ kg/dm}^3$ and kinematic viscosity $\gamma = 1 \text{ mm}^2/\text{sec}$.



SV60 SERIES (~ 2900 rpm)

MAIN CHARACTERISTICS

Working delivery 24 to 72 m³/h.

Maximum operating pressure, including water hammer on suction side:

– 16 bar.

AVAILABLE VERSIONS

- “F” : In-line ports, round flanges from SV6002 to SV6008.
- “N” : In-line ports, round flanges made of AISI 316 from SV6002 to SV6008.

TABLE OF MATERIALS

PART	“F” MATERIALS	“N” MATERIALS
Impeller	AISI 316 L	
Diffuser and upper spacer	AISI 316 L	
Shaft	AISI 431	AISI 316
Outer sleeve	AISI 304	AISI 316 L
Pump body	250 CAST IRON	CF - 8M (AISI 316 L)
Shaft sleeve	TUNGSTEN CARBIDE	
Bushing	CERAMIC	
Mechanical seal	SILICON CARBIDE/CARBON/EPDM	
Elastomers	EPDM	
Fill/drain plugs	NICKEL PLATED BRASS	AISI 316
Adapter	250 CAST IRON	
Coupling	200 CAST IRON	
Coupling protection	AISI 304	
Seal holding disk	–	AISI 316 L

ELECTRICAL SPECIFICATIONS

PUMP TYPE	MOTOR POWER		INPUT CURRENT In Amp.			Is/In
			THREE-PHASE			
			Δ 220-240 V	Y 380-415 V	Δ 380-415 V	
SV6002 F55T	5,5	132R	–	–	11,0	7,71
SV6003 F75T	7,5	132R	–	–	14,6	7,72
SV6004 F110T	11	160R	–	–	21,2	8,75
SV6005 F150T	15	160	–	–	28,6	8,56
SV6006 F150T	15	160	–	–	28,6	8,56
SV6007 F185T	18,5	160	–	–	34,2	8,80
SV6008 F220T	22	180R	–	–	40,3	8,61

* R = Reduced size of motor casing as compared to shaft extension and flange.

DIMENSIONS AND WEIGHTS

PUMP TYPE	DNA DNM	DIMENSIONS IN mm								WEIGHT (kg)	
		L1	L2	A	B	M	D1	D2	H	PUMP	ELECTRIC PUMP
SV6002 F55T	100	658	374	140	365	151	220	300	190	57	103
SV6003 F75T	100	730	374	140	365	151	220	300	190	60	110
SV6004 F110T	100	834	427	140	365	191	257	350	222	71	156
SV6005 F150T	100	906	488	140	365	232	310	350	222	74	166
SV6006 F150T	100	1170	488	140	365	232	310	350	222	87	179
SV6007 F185T	100	1242	532	140	365	232	310	350	222	90	189
SV6008 F220T	100	1314	532	140	365	232	310	350	222	94	208

“F” “N” VERSION

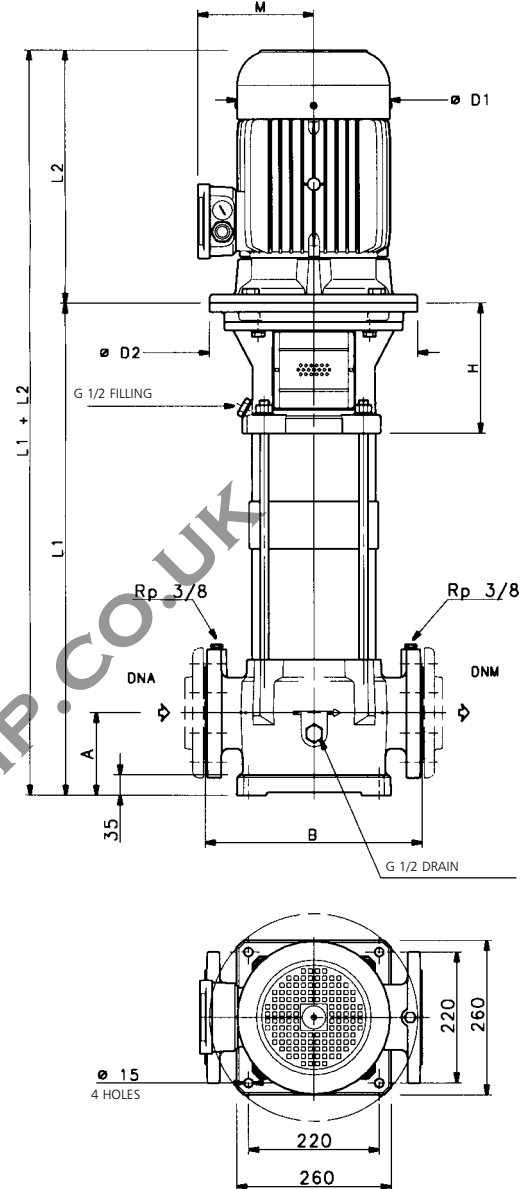

SV60 SERIES OPERATING CHARACTERISTICS AT 2900 rpm 50 Hz

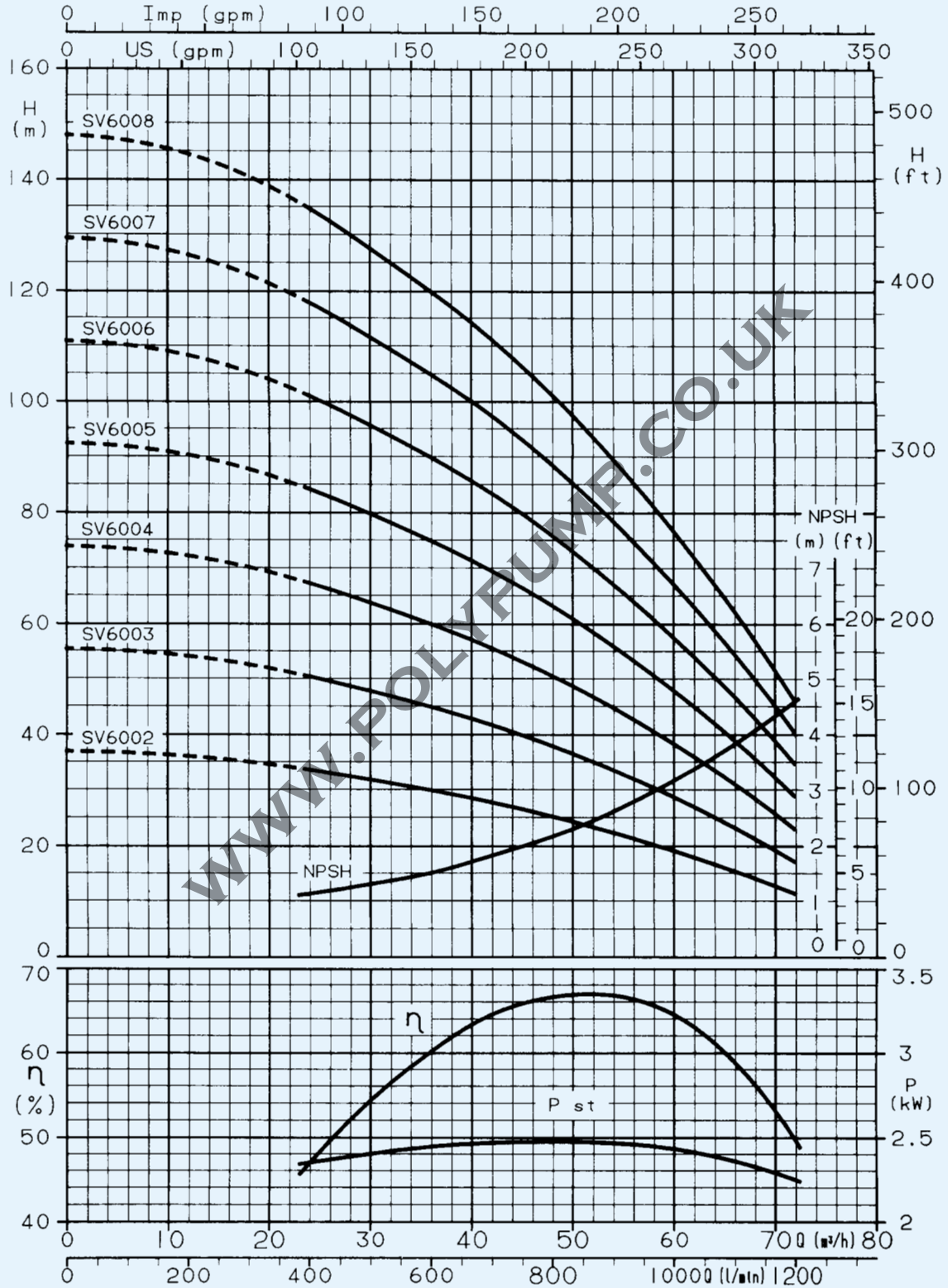

These performances are valid for liquids with density $\rho = 1.0 \text{ kg/dm}^3$ and kinematic viscosity $\gamma = 1 \text{ mm}^2/\text{sec}$.

