

"GRINDER" SERIES

SUBMERSIBLE PUMP FOR DIRTY WATER CONTAINING SOLIDS

Manufactured in cast iron, open multi-channel impeller with a grinder.

Powers up to 7,5 kW (10 HP).

APPLICATIONS

- Capacities up to 1 ÷ 4,4 L/s head up to 15 ÷ 50 m.
- Pump operates with a grinder for dirty water that contains fibres and solids.

SPECIFICATIONS

- 10 metres of cable with 7 wires.
- Mechanical seal system (2 mechanical seals).
- Dry motor, class F, 2 poles (2850 rpm).
- Single phase version up to 2 kW with float switch (FDLTM).

OPTIONAL ACCESSORIES

-  Explosion proof version (according to EN 50014).
- Cast iron support foot 2" (50 mm).
- Cast iron counterflange 1 1/2" (40 mm).
- Cast iron elbow 1 1/2" (40 mm).

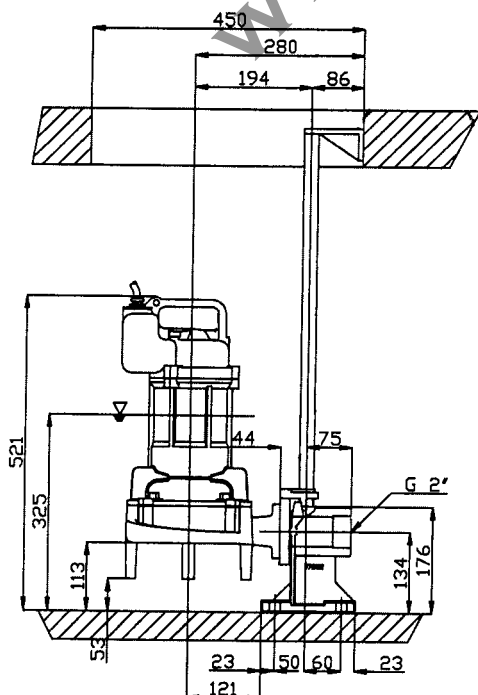

SUBMERSIBLE ELECTRIC PUMPS GRINDER, 1"1/2, R.P.M. 2850

Construction in CAST IRON G250 UNI ISO 185

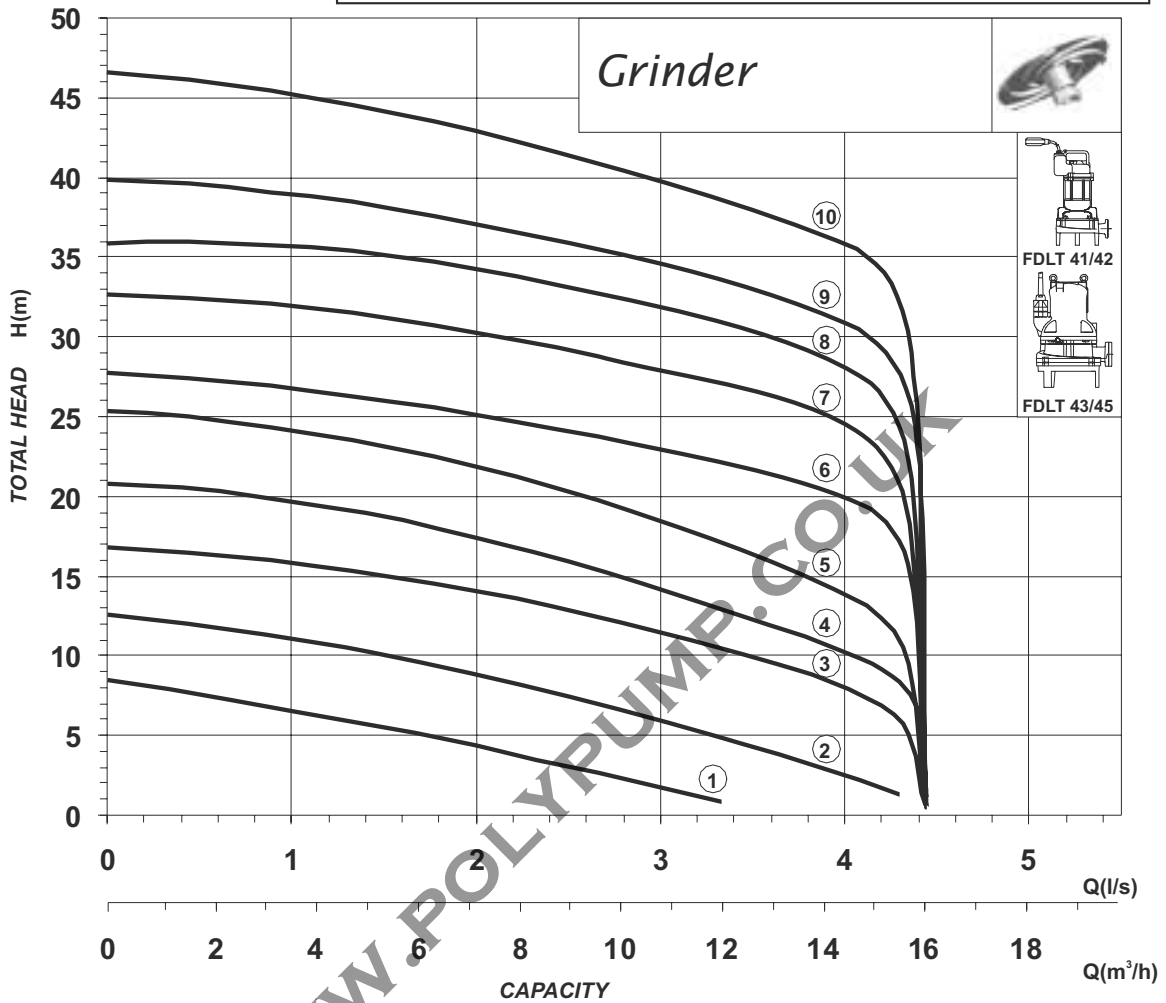

Curve N°	Pump Type	Input Power kW	Nom. Current A	Power Supply	Rotation Speed R.P.M.	Free Passage mm	Outlet Diameter mm	Weight Kg	Installation
1	FDLMT 41-23	0,8	3,7	1ph 230V- 50 Hz	2850	6	40	33	S-R
1	FDLT 41-23	0,8	2,3	3ph 400V- 50 Hz	2850	6	40	33	S-R
2	FDLMT 41-22	1,1	4,5	1ph 230V- 50 Hz	2850	6	40	34	S-R
2	FDLT 41-22	1,1	2,5	3ph 400V- 50 Hz	2850	6	40	33	S-R
3	FDLMT 41-21	1,4	6,3	1ph 230V- 50 Hz	2850	6	40	34	S-R
3	FDLT 41-21	1,4	2,9	3ph 400V- 50 Hz	2850	6	40	34	S-R
4	FDLMT 42-22	1,5	7,1	1ph 230V- 50 Hz	2850	6	40	34	S-R
4	FDLT 42-22	1,5	3	3ph 400V- 50 Hz	2850	6	40	34	S-R
5	FDLMT 42-21	2	9,1	1ph 230V- 50 Hz	2850	6	40	34	S-R
5	FDLT 42-21	2	3,8	3ph 400V- 50 Hz	2850	6	40	34	S-R
6	FDLT 43-22	2,5	4,5	3ph 400V- 50 Hz	2850	7	40	45	S-R
7	FDLT 43-21	3,2	5,5	3ph 400V- 50 Hz	2850	7	40	45	S-R
8	FDLT 44-22	3,8	7	3ph 400-690 V- 50 Hz	2850	7	40	60	S-R
9	FDLT 44-21	4,2	7,5	3ph 400-690 V- 50 Hz	2850	7	40	60	S-R
10	FDLT 45-21	4,9	8,6	3ph 400-690 V- 50 Hz	2850	7	40	60	S-R

Note:
S: Fixing kit

R: Lowering device with sliding guides