

DN SERIES

SUBMERSIBLE PUMPS FOR DIRTY WATER

Drainage pumps with up to 20 metre head and up to 280 l/min (15 m³/h) delivery.

This range consists of three pumps with up to 0.75 kW (1HP) rated power.

APPLICATIONS

- Draining of flooded excavations and marshy ground.
- Irrigation from rainwater reservoirs, ditches, ponds and watercourses.

SPECIFICATIONS

- Open **impeller** with **abrasion-resistant** rubber coating.
- Squirrel cage **motor** in a dielectric non-toxic **oil cooled**, which ensures the lubrication of the ball bearings and more efficient cooling.
- **IP 68 protection.**
- Mechanical seal protected by sand labyrinth.
- Maximum **immersion depth: 5 m.**
- **Maximum liquid temperature.**
50°C with fully submerged pump.
25°C with partially submerged pump.
- Versions:

Single-phase 220-240 V 50 Hz, with built-in automatic reset overload protection and capacitor housed in a control box on the cable.

Three-phase 220-240 or 380-415 V 50 Hz.

Overload protection to be provided by user and installed in the control box.

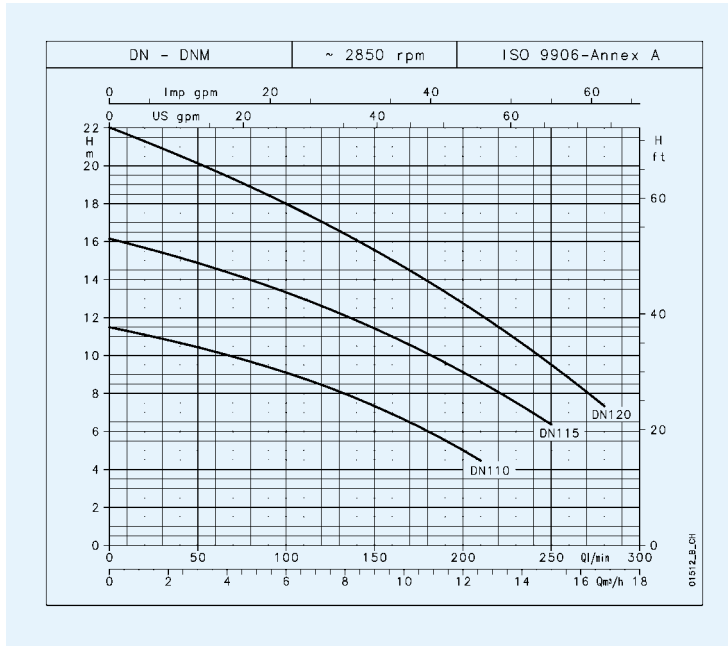

TABLE OF MATERIALS

PART	MATERIAL
Pump body	200 UNI ISO 185 CAST IRON*
Impeller	STEEL + NITRILE RUBBER
Wear flange, Suction screen, Motor casing	STAINLESS STEEL (AISI 304 - DIN 1,4301)
Mechanical seal	CARBON/CERAMIC/ NITRILE RUBBER
O-ring	NITRILE RUBBER
Shaft extension	STAINLESS STEEL (AISI 303 - DIN 1.4305)

* Cast iron, coated with polybutadiene varnish by electrophoresis at 180°C.

OPERATING CHARACTERISTICS AT 2850 rpm 50 Hz



PUMP TYPE	RATED POWER		Q = DELIVERY												
			l/min	0	25	50	75	100	125	150	175	210	225	250	280
			m ³ /h	0	1.5	3	4.5	6	7.5	9	10.5	12.6	13.5	15	16.8
			H = TOTAL HEAD METERS COLUMN OF WATER												
DN(M) 110	0.6	0.8	11.5	11.0	10.4	9.8	9.1	8.3	7.3	6.3	4.5				
DN(M) 115	0.6	0.8	16.2	15.6	14.9	14.1	13.3	12.4	11.4	10.3	8.6	7.8	6.4		
DN(M) 120	0.75	1	22.0	21.1	20.1	19.1	18.0	16.8	15.6	14.2	12.1	11.2	9.5	7.3	

These performances are valid for liquids with density $\rho = 1.0 \text{ kg/dm}^3$ and kinematic viscosity $\gamma = 1 \text{ mm}^2/\text{sec}$.

dn-2p50_a_th

PUMP TYPE	INPUT POWER*	INPUT CURRENT*	CAPACITOR
DNM 110	0.68	3.56	25
DNM 115	0.90	4.28	25
DNM 120	1.03	4.77	25

* Maximum value in specified range

PUMP TYPE	INPUT POWER*	INPUT CURRENT*	INPUT CURRENT*
DN 110	0.66	-	2.00
DN 115	0.93	-	2.20
DN 120	1.09	4.05	2.34

dn-2p50_a_te

DN SERIES DIMENSIONS AND WEIGHTS

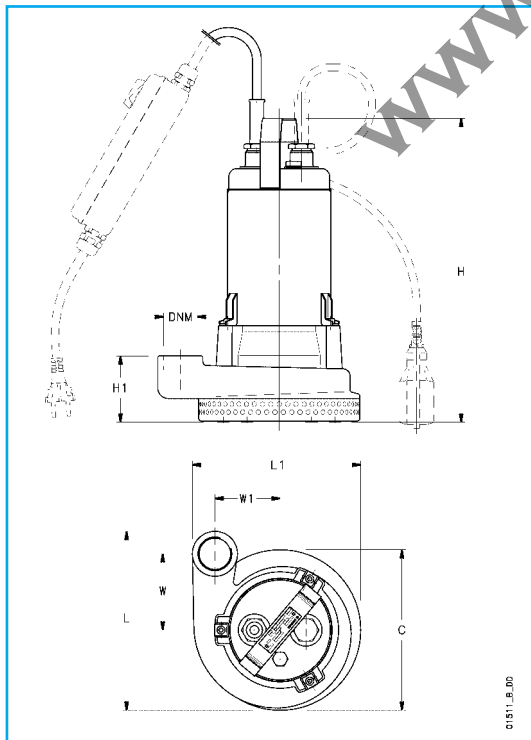

PUMP TYPE	DIMENSIONS (mm)								DNM	WEIGHT
	C	H	H1	L	L1	W	W1			
DNM110-DN110	Ø 200	380	81	209	223	81	95	Rp 1 1/4	18.5	
DNM115-DN115	Ø 200	380	81	209	223	81	95	Rp 1 1/4	18.5	
DNM120-DN120	Ø 200	380	81	209	223	81	95	Rp 1 1/4	19.5	

dn-2p50_a_td