

DIMENSIONS AND WEIGHTS

NOVA 180

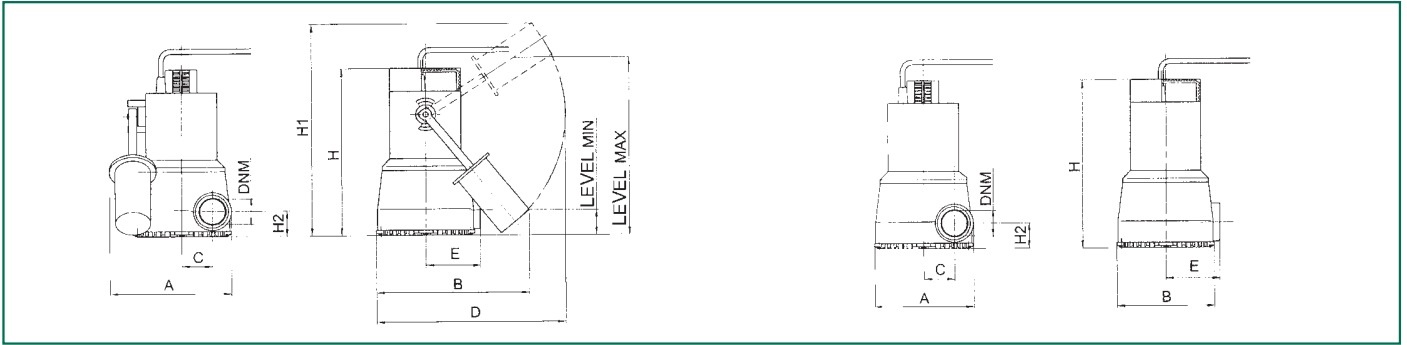

NOVA 200

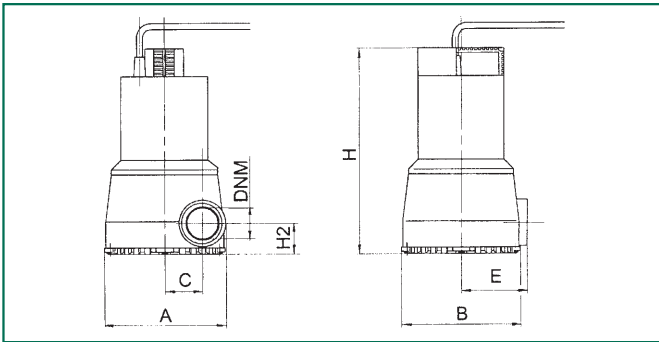

NOVA 300

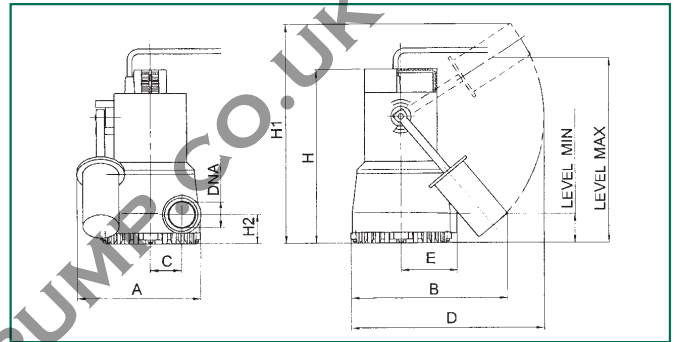

NOVA 600

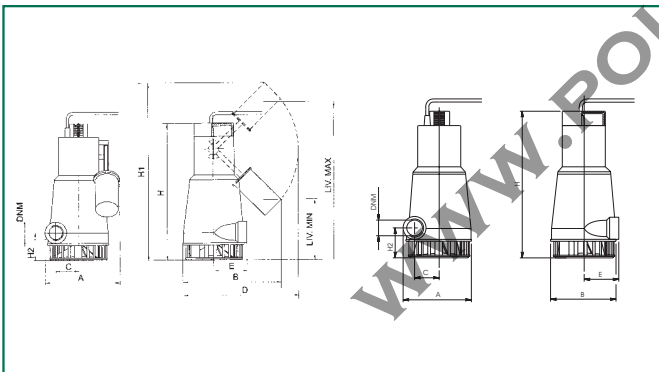

FEKA 600

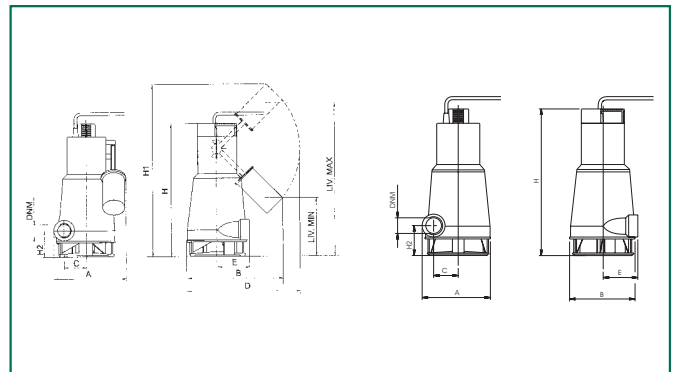

MODEL	A	B	C	D	E	H	H1	H2	LEVEL MIN.	LEVEL MAX.	DNM	PACKAGING DIMENSIONS			VOLUME m ³	WEIGHT Kg
												L/A	L/B	H		
NOVA 180 M-A	181	235	46	296	82	253	345	38	77	277	1/4"G	287	202	320	0,019	4,6
NOVA 180 M-NA	148	148	46	-	82	253	-	38	-	-	1/4"G	287	202	320	0,019	4,5
NOVA 180 M-A SV *	181	235	46	296	82	253	345	38	77	277	1/4"G	287	202	320	0,019	4,6
NOVA 180 M-NA SV *	148	148	46	-	82	253	-	38	-	-	1/4"G	287	202	320	0,019	4,5
NOVA 200 M-NA SV *	148	148	46	-	82	253	-	38	-	-	1/4"G	287	202	320	0,019	4,5
NOVA 200 M-A	181	235	46	296	82	262	354	47	85	285	1/4"G	287	202	320	0,019	4,6
NOVA 200 M-A SV *	181	235	46	296	82	262	354	47	85	285	1/4"G	287	202	320	0,019	4,6
NOVA 600 M-A	193	235	56	296	90	368	443	73	190	390	1/4"G	287	202	431	0,025	7
NOVA 600 (M-T)-NA	162	160	56	-	90	368	-	73	-	-	1/4"G	287	202	431	0,025	6,7
NOVA 600 M-A SV *	193	235	56	296	90	368	443	73	190	390	1/4"G	287	202	431	0,025	7
NOVA 600 (M-T)-NA SV *	162	160	56	-	90	368	-	73	-	-	1/4"G	287	202	431	0,025	6,7
FEKA 600 M-A	193	235	56	296	90	368	443	73	190	390	1/4"G	287	202	431	0,025	7
FEKA 600 (M-T)-NA	162	160	56	-	90	368	-	73	-	-	1/4"G	287	202	431	0,025	6,7
FEKA 600 M-A SV *	193	235	56	296	90	368	443	73	190	390	1/4"G	287	202	431	0,025	7
FEKA 600 (M-T)-NA SV *	162	160	56	-	90	368	-	73	-	-	1/4"G	287	202	431	0,025	6,7

* With special stainless steel motor shaft.