

K TWIN IMPELLER PUMPS

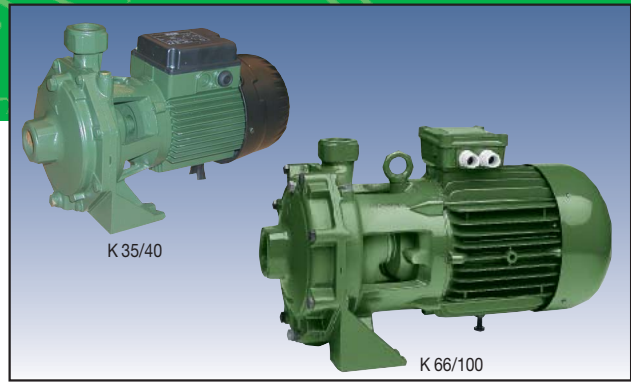

Twin impeller centrifugal pump designed for use in pressurisation units for water supply systems for domestic, civil and industrial use. Suitable for sprinkling irrigation and other water supply applications. Cast iron pump body and motor support. Technopolymer impeller.

Stainless steel driving shaft. Carbon/ceramic mechanical seal.

Asynchronous, closed motor, cooled by external ventilation.

Built-in thermal and current overload protection and a capacitor permanently on in the single-phase version. For the protection of the three-phase motor it is advisable to use a suitable overload protection complying with the regulations in force.

Operating range: from 1.2 to 30 m³/h with head up to 97 metres.

Pumped liquid characteristics: clean, free from solids or abrasive substances, not viscous, not aggressive, not crystallised, chemically neutral and close to the characteristics of water.

Liquid temperature range:

from -10°C to +50°C: for K 35/40, K 45/50, K 35/100, K 40/100, K 55/100

from -15°C to +110°C: for K 55/50, K 66/100, K 90/100, K 70/300, K 80/300, K 70/400, K 80/400

Maximum operating range: K 35/40, K 35/100, K 40/100: 6 bar (600 kPa)
K 45/50, K 55/50: 8 bar (800 kPa)

K 55/100, K 66/100: 10 bar (1000 kPa)

K 90/100, K 70/300, K 80/300

K 70/400, K 80/400: 12 bar (1200 kPa)

Maximum ambient temperature: +40°C

Protection level: IP 44

Terminal board protection level: IP 55

Insulation class: F

TECHNICAL DATA

| MODEL | ELECTRICAL DATA | | | | | | |
|------------|------------------|-----------------|------------------------|------|----------|--------------------|-----|
| | VOLTAGE 50 Hz | P1 MAX kW | P2 NOMINAL kW HP | | In A | CAPACITOR µF Vc | |
| K 35/40 M | 1x220-240 V~ | 1,2 | 0,75 | 1 | 5,5 | 20 | 450 |
| K 35/40 T | 3x230-400 V~ | 1,2 | 0,75 | 1 | 3,8-2,2 | - | - |
| K 45/50 M | 1x220-240 V~ | 1,86 | 1,1 | 1,5 | 8,3 | 31,5 | 450 |
| K 45/50 T | 3x230-400 V~ | 1,96 | 1,1 | 1,5 | 6-3,5 | - | - |
| K 55/50 M | 1x220-240 V~ | 2,7 | 1,85 | 2,7 | 12,8 | 40 | 450 |
| K 55/50 T | 3x230-400 V~ | 2,5 | 1,85 | 2,5 | 8,4-4,8 | - | - |
| K 35/100 M | 1x220-240 V~ | 1,56 | 1,1 | 1,5 | 7,1 | 25 | 450 |
| K 35/100 T | 3x230-400 V~ | 1,56 | 1,1 | 1,5 | 5,36-3,1 | - | - |
| K 40/100 M | 1x220-240 V~ | 2 | 1,85 | 2,5 | 9 | 40 | 450 |
| K 40/100 T | 3x230-400 V~ | 2 | 1,85 | 2,5 | 6,2-3,6 | - | - |
| K 55/100 T | 3x230-400 V~ | 3,9 | 2,2 | 3 | 11,6-6,7 | - | - |
| K 66/100 T | 3x230-400 V~ | 4,7 | 3 | 4 | 14,6-8,4 | - | - |
| K 90/100 T | 3x230-400 V~ | 5,4 | 4 | 5,5 | 16,5-9,5 | - | - |
| K 70/300 T | 3x400 V ~ Δ* | 7,1 | 5,5 | 7,5 | 12,9 | - | - |
| K 80/300 T | 3x400 V ~ Δ* | 9,9 | 7,5 | 10 | 15 | - | - |
| K 70/400 T | 3x400 V ~ Δ* | 10,7 | 9,2 | 12,5 | 18 | - | - |
| K 80/400 T | 3x400 V ~ Δ* | 12,5 | 11 | 15 | 21 | - | - |

* Star (Δ) starting is possible

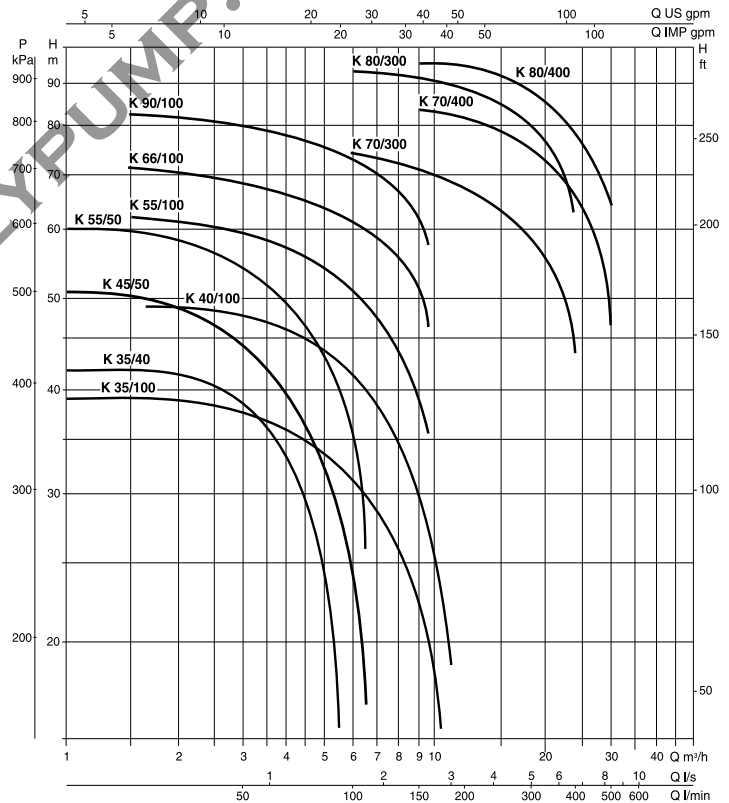

DIMENSIONS AND WEIGHTS

K 35/40

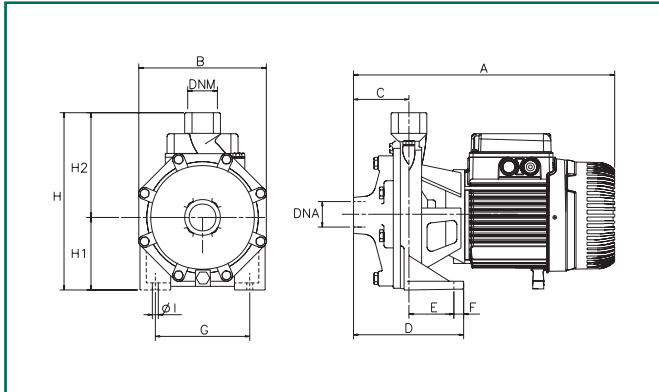

K 45/50 - 55/50 - 66/100 - 90/100

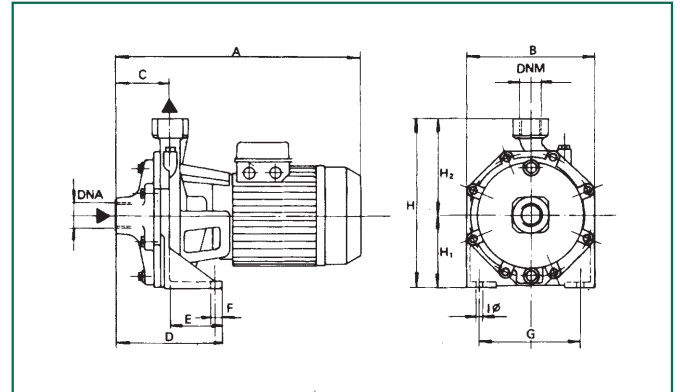

K 35/100 - 40/100

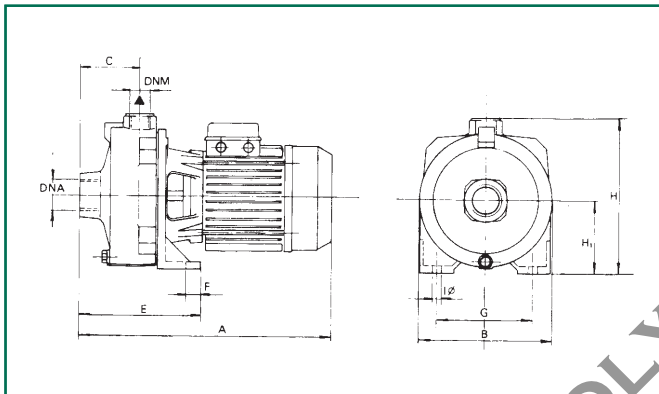

K 70/300 - 80/300 - 70/400 - 80/400

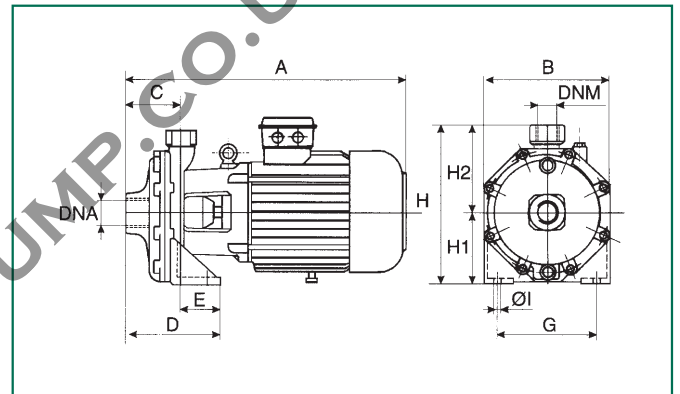

| MODEL | A | B | C | D | E | F | G | ØI | H | H1 | H2 | DNA | DNM | WEIGHT Kg |
|-------------------|-----|-----|-----|-----|-----|----|-----|------|-------|-----|-------|----------|----------|-----------|
| K 35/40 | 342 | 180 | 76 | 148 | 72 | 15 | 148 | 9,5 | 235 | 100 | 135 | 1" G | 1" G | 15,9 |
| K 45/50 | 370 | 210 | 75 | 144 | 69 | 15 | 165 | 11,5 | 268 | 118 | 150 | 1 1/4" G | 1" G | 23,3 |
| K 55/50 | 370 | 210 | 75 | 114 | 69 | 15 | 165 | 11,5 | 268 | 118 | 150 | 1 1/4" G | 1" G | 23,8 |
| K 35/100 | 387 | 205 | 88 | - | 179 | 20 | 145 | 11 | 233 | 108 | - | 1 1/2" G | 1" G | 21,5 |
| K 40/100 M | 461 | 205 | 88 | - | 179 | 20 | 145 | 11 | 233 | 108 | - | 1 1/2" G | 1" G | 25,9 |
| K 40/100 T | 387 | 205 | 88 | - | 179 | 20 | 145 | 11 | 233 | 108 | - | 1 1/2" G | 1" G | 22 |
| K 55/100 | 450 | 256 | 88 | 160 | 72 | 18 | 200 | 14 | 312,5 | 140 | 172,5 | 1 1/2" G | 1" G | 37,1 |
| K 66/100 | 450 | 256 | 88 | 160 | 72 | 18 | 200 | 14 | 312,5 | 140 | 172,5 | 1 1/2" G | 1" G | 39,7 |
| K 90/100 | 450 | 256 | 88 | 160 | 72 | 18 | 200 | 14 | 312,5 | 140 | 172,5 | 1 1/2" G | 1" G | 43 |
| K 70/300 | 595 | 270 | 122 | 182 | 60 | 20 | 210 | 14 | 340 | 160 | 180 | 2" G | 1 1/4" G | 72 |
| K 80/300 | 595 | 270 | 122 | 182 | 60 | 20 | 210 | 14 | 340 | 160 | 180 | 2" G | 1 1/4" G | 78,5 |
| K 70/400 | 635 | 270 | 122 | 182 | 60 | 20 | 210 | 14 | 340 | 160 | 180 | 2" G | 1 1/4" G | 74 |
| K 80/400 | 635 | 270 | 122 | 182 | 60 | 20 | 210 | 14 | 340 | 160 | 180 | 2" G | 1 1/4" G | 78 |