

# FEKAFOS 550

## AUTOMATIC STATIONS FOR COLLECTING AND LIFTING WASTE WATERS



Automatic collection and lifting stations, used for collecting and pumping civil and industrial waste water in sewers.

Comprises a high density 550 litre polythene tank with 2 removable covers complete with a watertight and gastight seal. Complete with 2 lifting devices (DSD2) for making pump maintenance easier. Fitted for two non-automatic electric pumps (FEKA 600 M-NA - FEKA 700 M-NA - FEKA 800 M-NA - FEKA 900 M-NA FEKA/GRINDER 1400/1800) to be ordered separately.

Complete with: 3 bulb floats mounted on a stainless steel support, cable holder for connecting the float and pump cables to the electrical panel (to order separately according to the table).



Complete with DN50 and DN110 suction manifolds and 2" delivery manifolds.

Complete with connector for DN50 vent tube.

An alarm float can be used on request.

**Operating range:** from 1 to 65 m<sup>3</sup>/h with a head of up to 26.5 m

**Liquid temperature range:** +55°C

**Pumped liquid:** ground water, rain water, clear waste water, black waste water and water from rivers and lakes.

### DIMENSIONS AND WEIGHTS

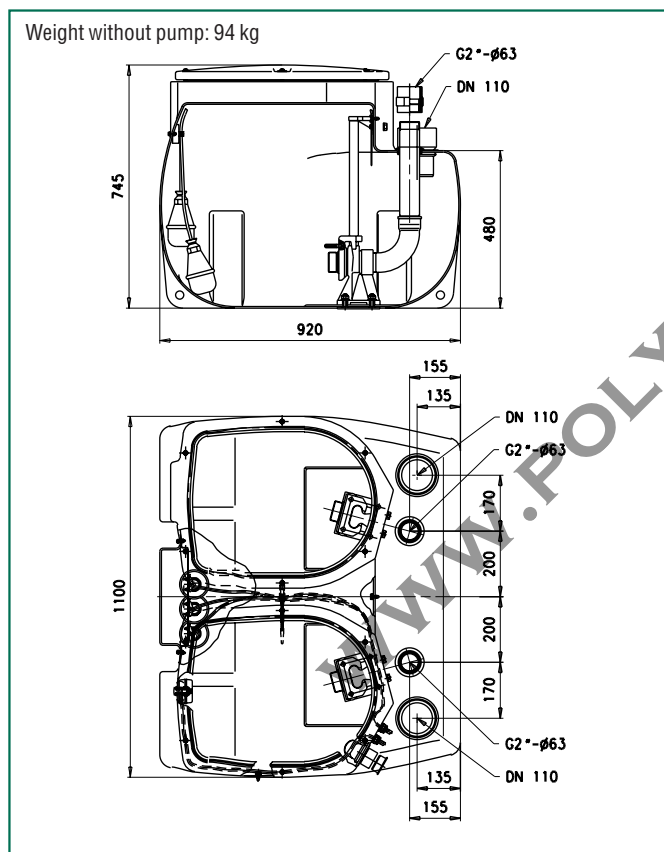

### HYDRAULIC DATA

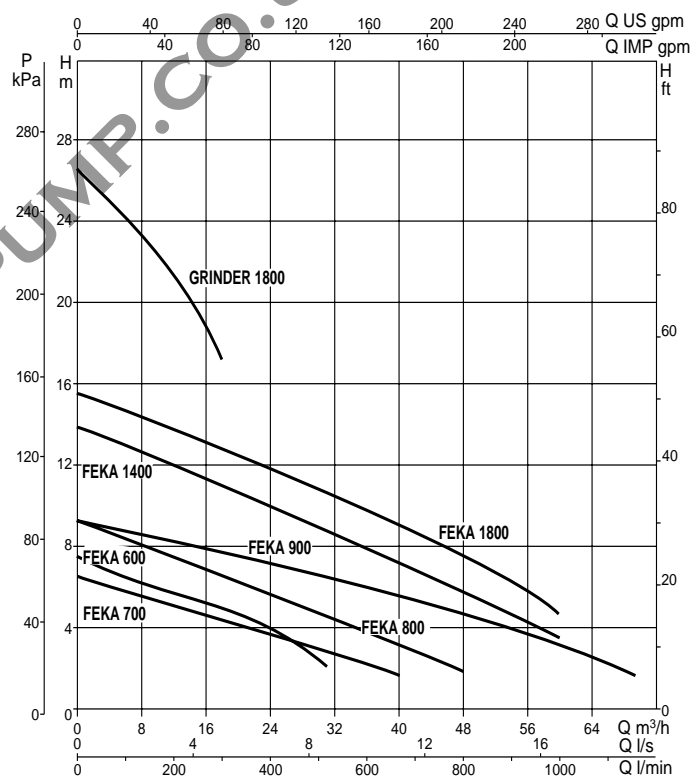

### PUMP SELECTION/CONTROL PANEL

| MODEL         | P2 NOMINAL |      | CONTROL PANEL SINGLE-PHASE 230V-50 Hz | CONTROL PANEL THREE-PHASE 400V-50 Hz |
|---------------|------------|------|---------------------------------------|--------------------------------------|
|               | kW         | HP   |                                       |                                      |
| FEKA 600 N.A. | 0,55       | 0,75 | E2D 2,6 M                             | E2D2 T                               |
| FEKA 700 N.A. | 0,6        | 0,8  | E2D 2,6 M                             | E2D2 T                               |
| FEKA 800 N.A. | 0,75       | 1    | E2D 2,6 M                             | E2D3 T                               |
| FEKA 900 N.A. | 1          | 1,36 | E2D 2,6 M                             | E2D3 T                               |
| FEKA 1400     | 1,1        | 1,5  | E2D 6 M                               | -                                    |
| FEKA 1800     | 1,5        | 2    | -                                     | E2D5 T                               |
| GRINDER 1800  | 1,5        | 2    | -                                     | E2D5 T                               |