

# FEKAFOS 280

## AUTOMATIC STATIONS FOR COLLECTING AND LIFTING WASTE WATERS

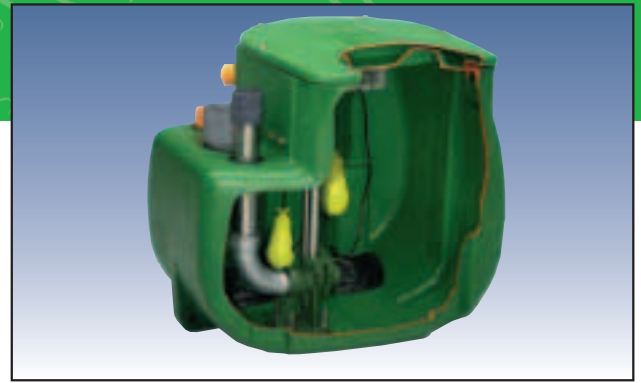

Automatic collection and lifting stations, used for collecting and pumping civil and industrial waste water in sewers.

Comprises a high density 280 litre polythene tank with removable cover complete with a watertight and gastight seal. Complete with lifting device (DSD2) for making pump maintenance easier. Fitted for one non-automatic electric pump (FEKA 600 M-NA - FEKA 700 M-NA - FEKA 800 M-NA - FEKA 900 M-NA FEKA/GRINDER 1400/1800) to be ordered separately.

Complete with: 2 bulb floats mounted on a stainless steel support, cable holder for connecting the float and pump cables to the electrical panel (to order separately according to the table).

Complete with DN50 and DN110 suction manifolds and 2" delivery manifolds.

Complete with connector for DN50 vent tube.

An alarm float can be used on request.

**Operating range:** from 1 to 35 m<sup>3</sup>/h with a head of up to 26.5 m

**Liquid temperature range:** +55°C

**Pumped liquid:** ground water, rain water, clear waste water, black waste water and water from rivers and lakes.

### DIMENSIONS AND WEIGHTS

Weight without pump: 41 kg

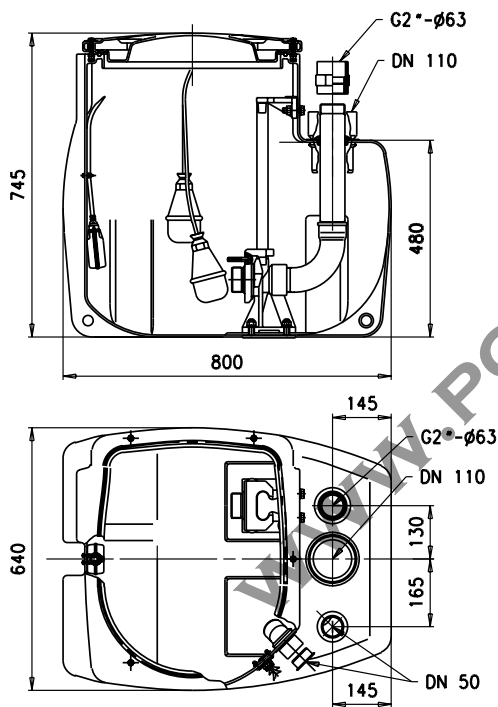

### HYDRAULIC DATA

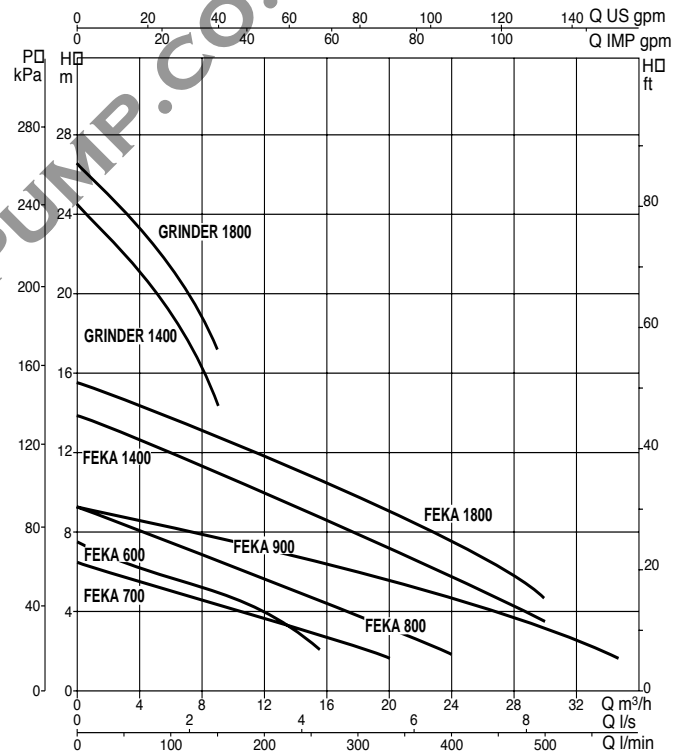

### PUMP SELECTION/CONTROL PANEL

MODEL	P2 NOMINAL		CONTROL PANEL SINGLE-PHASE 230V~50 Hz	CONTROL PANEL THREE-PHASE 400V~50 Hz
	kW	HP		
FEKA 600 N.A.	0,55	0,75	ED 1,3 M	ED 1 T
FEKA 700 N.A.	0,6	0,8	ED 1,3 M	ED 1 T
FEKA 800 N.A.	0,75	1	ED 1,3 M	ED 1,5 T
FEKA 900 N.A.	1	1,36	ED 1,3 M	ED 1,5 T
FEKA 1400	1,1	1,5	ED 3 M	-
FEKA 1800	1,5	2	-	ED 2,5 T
GRINDER 1400	1,1	1,5	ED 3 M Hs	-
GRINDER 1800	1,5	2	-	ED 2,5 T