

DRENAG 900

STAINLESS STEEL SUBMERSIBLE PUMP



Pump body, impeller, motor flange, filter and filter cover, motor casing, outer casing with handle, cable compartment cover in **AISI 304 stainless steel**.
 Driving motor in **AISI 316 stainless steel**.
 Handle coated with insulating rubber
Double mechanical seal with oil chamber interposed, carbon/alumina on motor side and silicon/silicon carbide on pump side.
Dry motor, asynchronous, watertight, cooled by the pumped liquid itself.
 Standard thermal protection in the winding.
 Capacitor permanently on in the single-phase version.
 10 metres of H07RN-F power cables with electric plug are supplied as a standard feature. All models can be supplied either with or without float.

Operating range: from 3 to 23 m³/h with head up to 14.2 metres

Liquid temperature range: from 0°C to +50°C
 from 0°C to +35°C for domestic use

Pumped liquid characteristics: rain water, phreatic water, sandy water from building yards and clean waste waters, not aggressive.

Maximum working temperature: +40°C with the motor out of the water

Granulometric passage through the suction grid: 12 mm

Maximum immersion depth: 10 metres

Protection level: IP 68

Insulation class: F

Installation: fixed or portable, in a vertical position

ELECTRICAL AND HYDRAULIC DATA

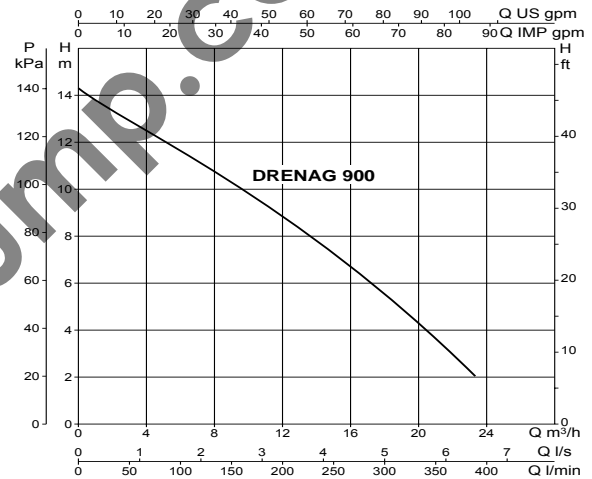

| MODEL | ELECTRICAL DATA | | | | | | HYDRAULIC DATA | | | | | | | | |
|---------------------|------------------|-----------------|------------------------|------|---------------------|--------------------|---------------------------------|------|----|------|------|----|-----|-----|-----|
| | VOLTAGE 50 Hz | P1 MAX kW | P2 NOMINAL kW HP | | I _n A | CAPACITOR μF Vc | Q m ³ /h l/min | 0 | 3 | 6 | 9 | 12 | 15 | 18 | 21 |
| DRENAG 900 M | 1x220-240 V ~ | 1,38 | 1 | 1,36 | 6 | 25 450 | H (m) | 14,2 | 13 | 11,8 | 10,5 | 9 | 7,3 | 5,4 | 3,5 |
| DRENAG 900 T | 3x400 V ~ | 1,37 | 1 | 1,36 | 2,5 | - - | | | | | | | | | |

INSTALLATION

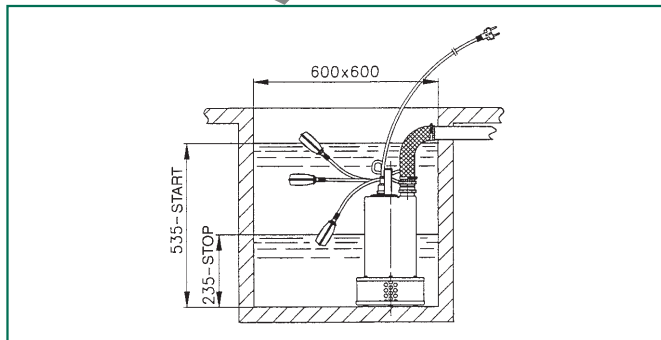

DIMENSIONS AND WEIGHTS

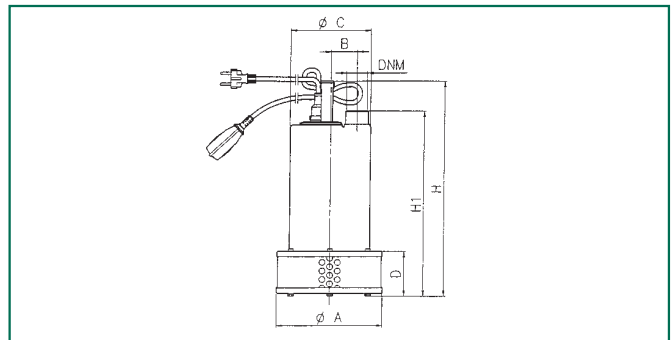

| MODEL | A | B | C | D | H | H1 | DNM | PACKAGING DIMENSIONS | | | VOLUME m ³ | WEIGHT Kg |
|-------------------|-----|------|-----|----|-----|-----|----------|----------------------|-----|-----|--------------------------|--------------|
| | | | | | | | | L/A | L/B | H | | |
| DRENAG 900 | 219 | 62,5 | 166 | 95 | 486 | 388 | 1 1/2" G | 522 | 246 | 307 | 0,040 | 17 |