

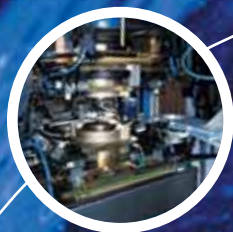

GP - GPE



Pressure boosting



UNITS WITH 2 CLOSE-COUPLED HORIZONTAL MULTISTAGE PUMPS, "COMPACT"-SERIES



*Tanks optional

TYPICAL APPLICATIONS

The unit's base plate is in galvanized steel, as are the manifolds. The discharge manifold is supplied ready to accommodate 2 vertical diaphragm tanks, where needed. 2 pressure switches, the control panel and a pressure gauge are fitted on it. Each motor-driven pump has an isolating valve and a nonreturn valve on suction, with the option of connecting an air feed, and features another isolating valve on discharge.

CE-MARKED PROTECTION AND CONTROL PANEL

- Components are IMQ and VDE certified.
- Very low voltage auxiliary circuit.
- Motors are switched on and off by two pressure switches.
- Float switches, or a low-limit pressure switch, can be connected to prevent operation when there is no water for suction.
- There is a device alternating the order pumps come on every time they are started.
- Power supply: - single-phase 230 V, 50Hz
- three-phase 400 V, 50Hz.
- Starting: - direct-on-line.
- Fuses protecting power circuit.
- Fuses protecting auxiliary circuit.
- Protection IP 55.
- Master line disconnecter with door lock.
- Auto - 0 - Hand switches for each pump.
- Thermal overload cutout reset.
- Indicator LED: - mains power on
- motor running
- level alarm
- motor cutout tripped
(for three-phase version only).
- Output provided for alarm warning.
- Special-version panels can be used on request.

THEORY OF OPERATION

If water is taken from the system, or leaks, with the pumps stopped, pressure drops and the contact of the pressure switch with the highest setting consequently closes, causing the first motor-driven pump to start. If the flow out is higher than the capacity of one pump, pressure will continue to drop until it causes the contact of the second pressure switch to close and hence the second pump to start. When delivery ends or the output flow is reduced, pressure in the system is raised, causing the contacts of the pressure switches to open and the pumps to stop in sequence. Reversing the order in which the two motors come on reduces the number of times the individual pumps start per hour and evens out pump operation. Connecting a float switch or minimum pressure switch to the control panel (both for drawing from the primary storage tank and from the water circuit) will prevent the most frequent cause of motor-driven pump failure: no water for suction

PERFORMANCE CURVES (according to ISO 9906 Annex A)

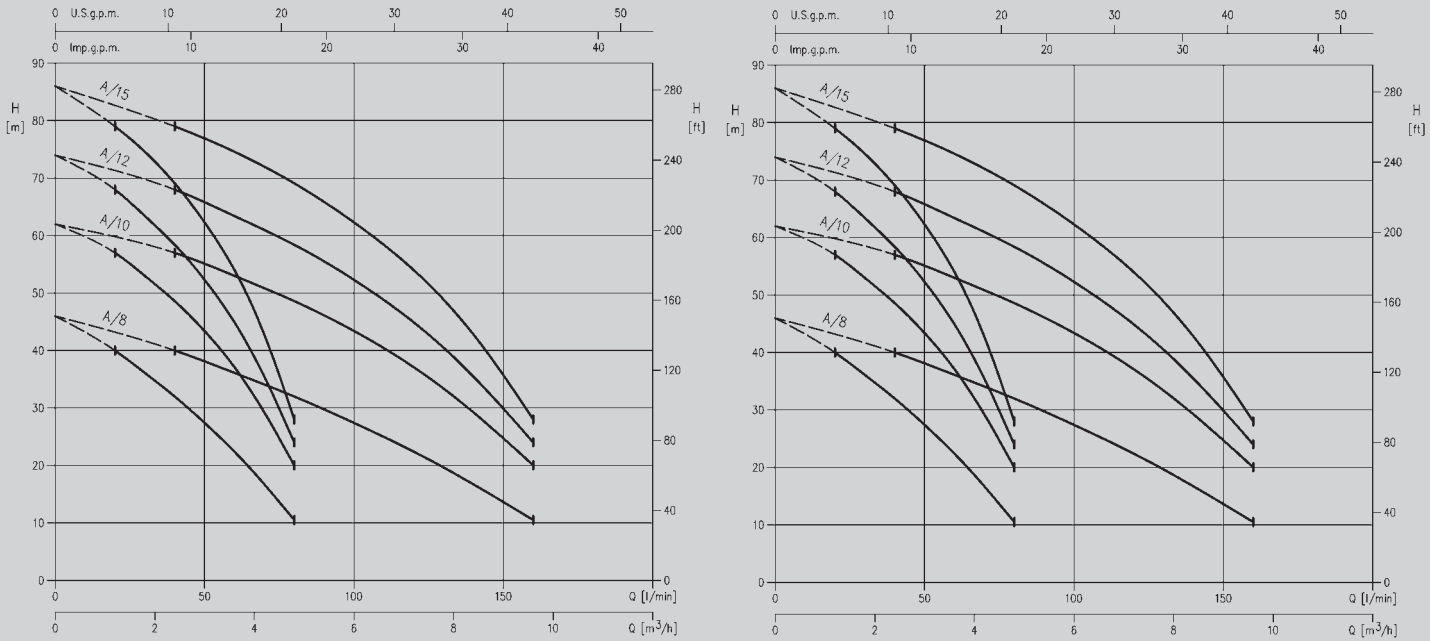

PERFORMANCE CHART FOR BOTH PUMPS WORKING AT THE SAME TIME

Type of pump		kW	Max. absorbed power (A)		Q=Flow rate							
Single-phase 230 V	Three-phase 400 V		Single-Phase 230 V	Three-phase 400 V	l/min m³/h	0	40	80	120	160	200	240
Compact AM 8	Compact A 8	0.60 + 0.6	8	3		0	2.4	4.8	7.2	9.6	12	14.4
Compact AM 10	Compact A 10	0.75 + 0.75	12	4.8		H=Total discharge head in mwc						
Compact AM 12	Compact A 12	0.88 + 0.88	12.4	5.4	46	39.7	32	22.4	10.5			
Compact AM 15	Compact A 15	1.1 + 1.1	14.6	6.6	62	56.5	48.6	37.1	20			
Compact BM 12	Compact B 12	0.88 + 0.88	11.6	5.4	74	67.5	58.4	44.9	24			
Compact BM 15	Compact B 15	1.1 + 1.1	14.6	6.8	86	79	69.1	54	28			
					51		45.9	41.3	35.2	27.6	18	
					63		56	51.5	44.5	34.5	22	

DIMENSION DRAWINGS

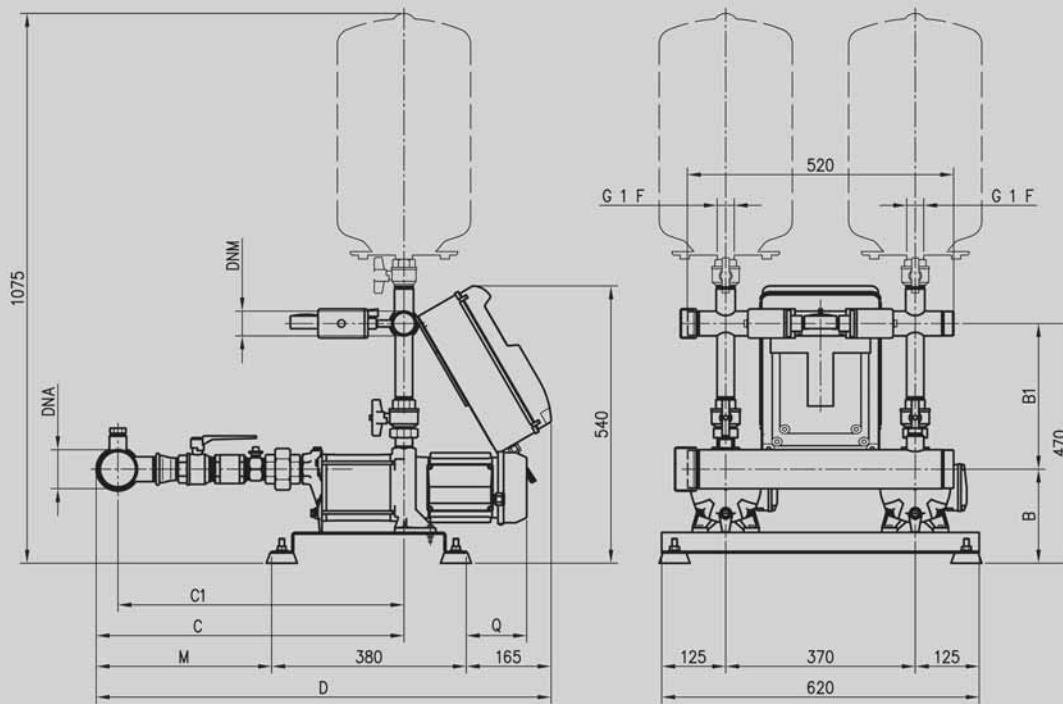

DIMENSION TABLE

Model	Dimensions (mm)								
	B	B1	C	C1	D	DNA	DNM	M	Q
2GP COMPACT A(M)8	190	280	525	490	815	G2	G1½	270	65
2GP COMPACT A(M)10	185	285	555	520	840	G2	G1½	295	105
2GP COMPACT A(M)12	185	285	580	545	865	G2	G1½	320	105
2GP COMPACT A(M)15	185	285	605	570	890	G2	G1½	345	120
2GP COMPACT B(M)12	185	285	575	530	860	G2½	G1½	315	105
2GP COMPACT B(M)15	185	285	600	560	890	G2½	G1½	345	120

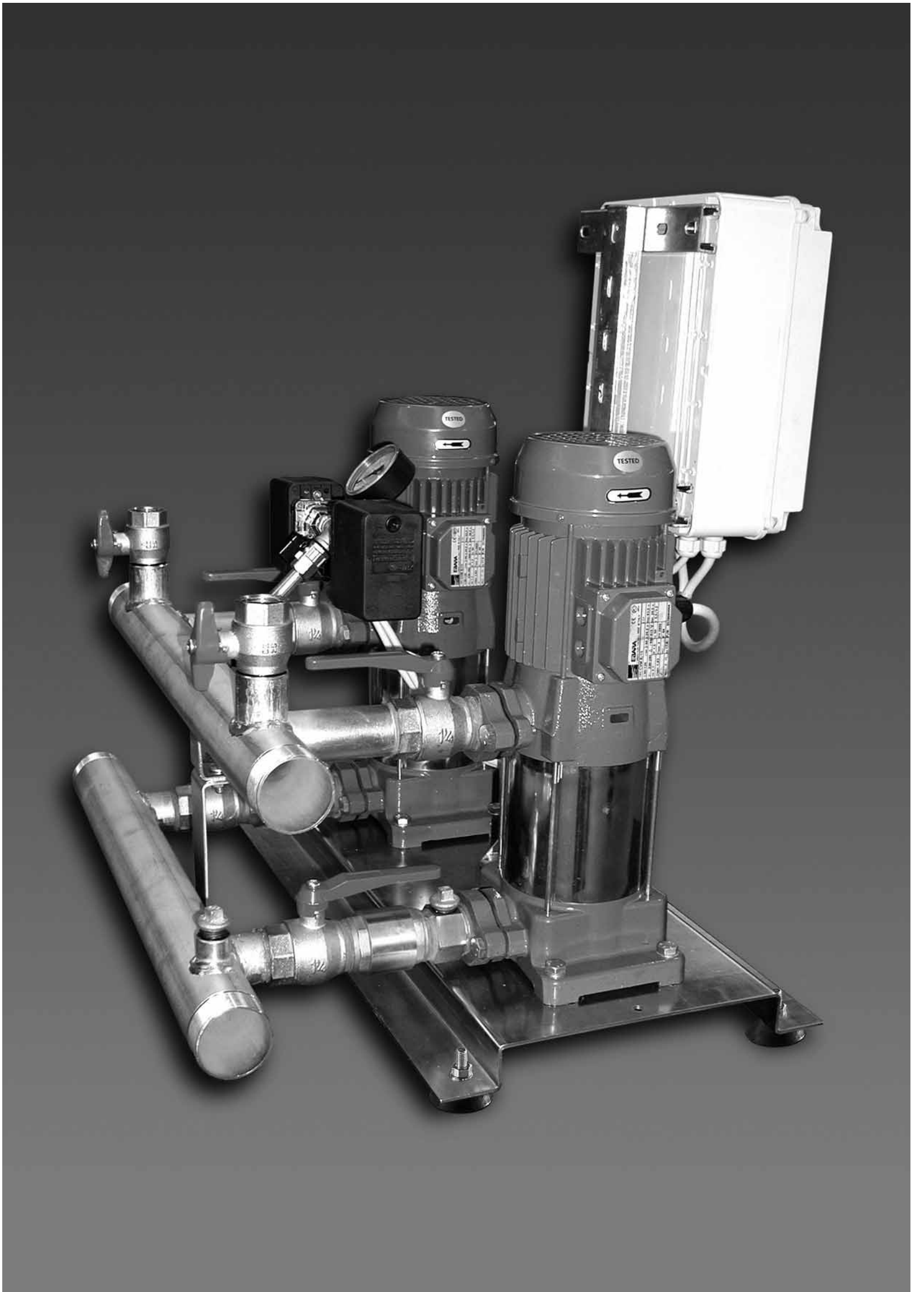

**UNITS WITH
2 VERTICAL
MULTISTAGE
PUMPS,
"CVM" SERIES**



TYPICAL APPLICATIONS

The unit's base plate is in galvanized steel, as are the manifolds. The discharge manifold is supplied ready to accommodate 2 vertical diaphragm tanks, where needed. 2 pressure switches, the control panel and a pressure gauge are fitted on it. Each motor-driven pump has an isolating valve and a nonreturn valve on suction, with the option of connecting an air feed, and features another isolating valve on discharge.

CE-MARKED PROTECTION AND CONTROL PANEL

- Components are IMQ and VDE certified.
- Very low voltage auxiliary circuit.
- Motors are switched on and off by two pressure switches.
- Float switches, or a low-limit pressure switch, can be connected to prevent operation when there is no water for suction.
- There is a device reversing the order pumps come on every time they are started.
- Power supply: - single-phase 230 V, 50Hz
- three-phase 400 V, 50Hz.
- Starting: - direct-on-line.
- Fuses protecting power circuit.
- Fuses protecting auxiliary circuit.
- Protection IP 55.
- Master line disconnecter with door lock.
- Auto - 0 - Hand switches for each pump.
- Thermal overload cutout reset.
- Indicator LED: - main power on
- motor running
- level alarm
- motor cutout tripped
(for three-phase version only).
- Output provided for alarm warning.
- Special-version panels can be used on request.

THEORY OF OPERATION

If water is taken from the system, or leaks, with the pumps stopped, pressure drops and the contact of the pressure switch with the highest setting consequently closes, causing the first motor-driven pump to start. If the flow out is higher than the capacity of one pump, pressure will continue to drop until it causes the contact of the second pressure switch to close and hence the second pump to start. When delivery ends or the output flow is reduced, pressure in the system is raised, causing the contacts of the pressure switches to open and the pumps to stop in sequence. Reversing the order in which the two motors come on reduces the number of times the individual pumps start per hour and evens out pump operation. Connecting a float switch or minimum pressure switch to the control panel (both for drawing from the primary storage tank and from the water circuit) will prevent the most frequent cause of motor-driven pump failure: no water for suction

CVM A63 PERFORMANCE CURVES (according to ISO 9906 Annex A)

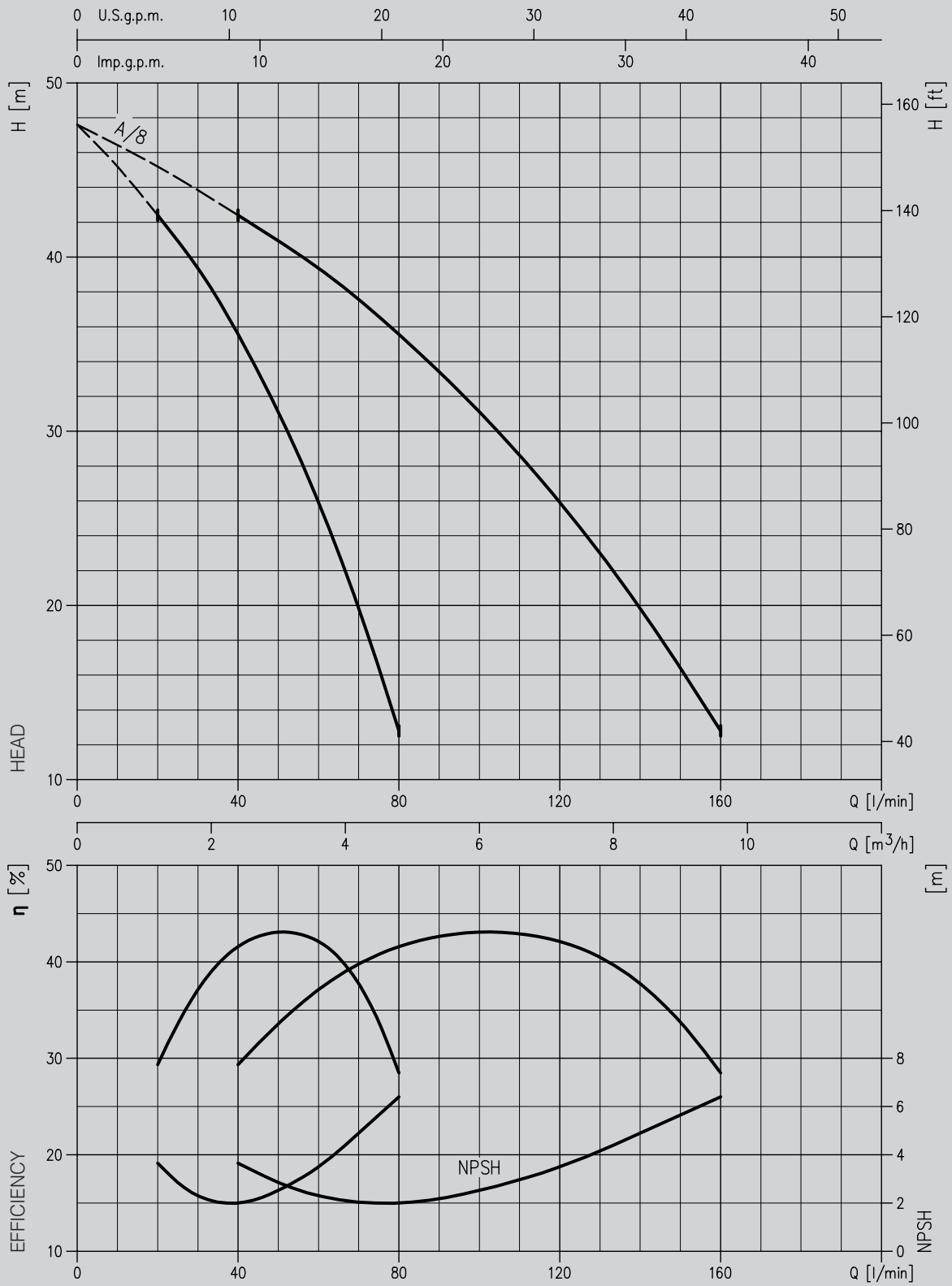

CVM A71

CVM A(M80) PERFORMANCE CURVES (according to ISO 9906 Annex A)

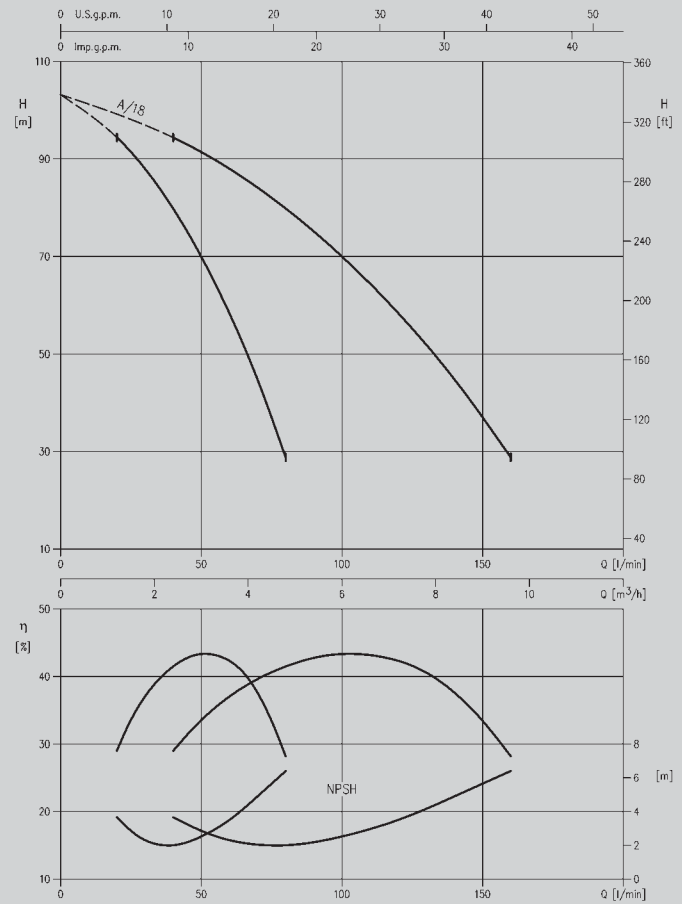
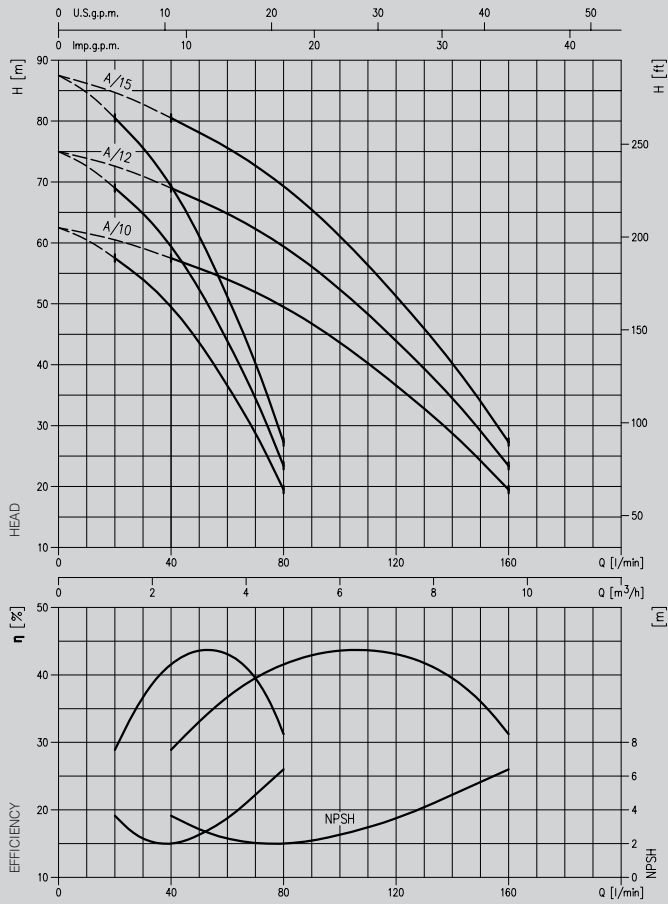

CVM B71

CVM B(M80) PERFORMANCE CURVES (according to ISO 9906 Annex A)

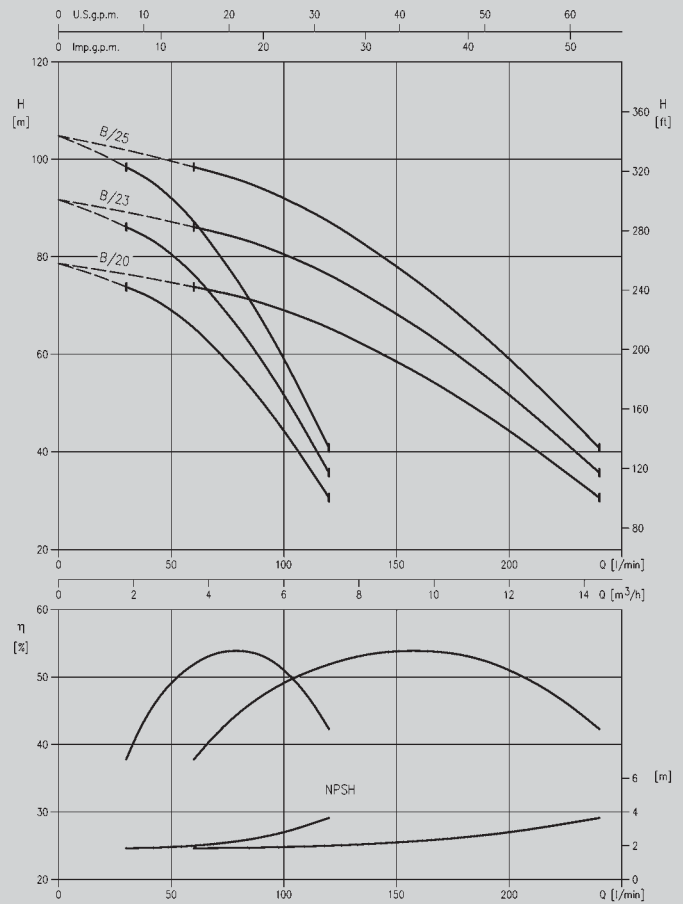
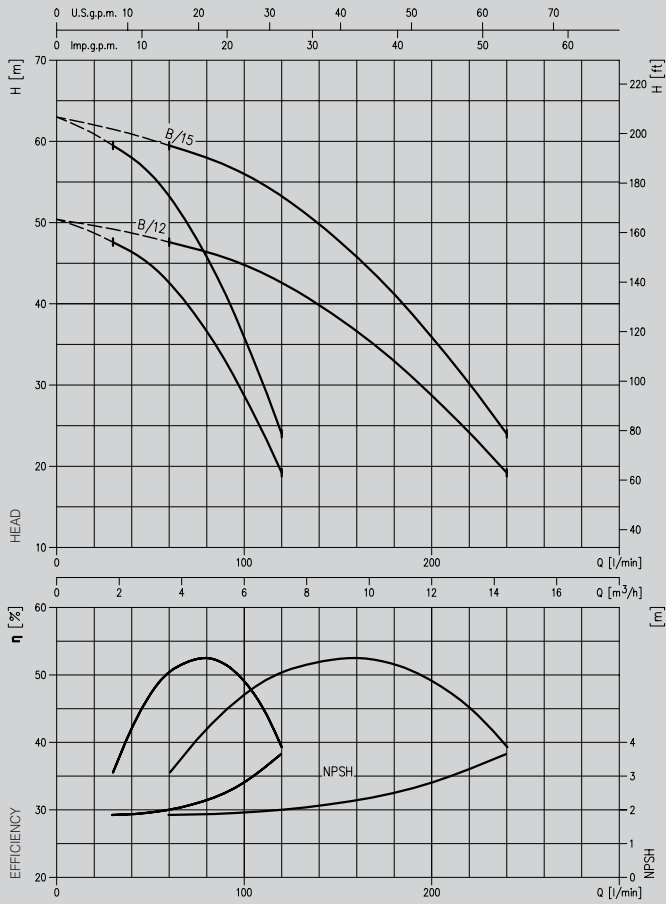

DIMENSION DRAWINGS

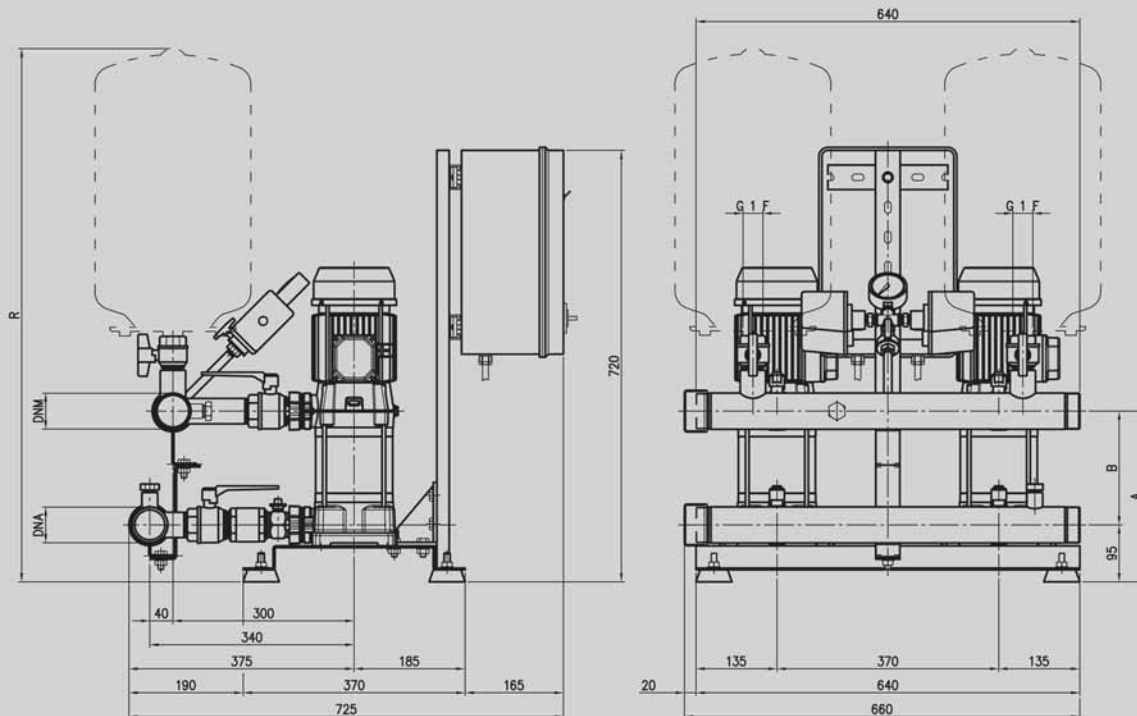

DIMENSION TABLE

Model	Dimensions (mm)					
	A	B	R	DNA	DNM	Weight (kg)
2GP CVM A(M)8	260	165	865	G2	G2	57
2GP CVM A(M)10	285	190	890	G2	G2	61
2GP CVM A(M)12	310	215	915	G2	G2	62
2GP CVM A(M)15	335	215	940	G2	G2	63
2GP CVM A(M)18	365	270	970	G2	G2	69
2GP CVM B(M)12	260	165	865	G2	G2	61
2GP CVM B(M)15	285	190	890	G2	G2	62
2GP CVM B(M)20	310	215	915	G2	G2	68
2GP CVM B(M)23	335	240	940	G2	G2	72
2GP CVM B25	365	270	970	G2	G2	74

PERFORMANCE CHART FOR BOTH PUMPS WORKING AT THE SAME TIME

Type of pump		kW	Max. abs.power (A)		l/min m³/h	Q=Flow rate								
Single-phase 230 V	Three-phase 400 V		Single-Phase 230 V	Three-phase 400 V		0	40	60	80	100	120	160	200	240
					H=Total discharge head in mwc									
CVM AM 8	CVM A 8	0.6 + 0.6	8	3	47.5	42.5	39.4	35.6	31.1	25.9	12.8	-	-	
CVM AM 10	CVM A 10	0.75 + 0.75	12	4.8	62.5	57.5	54.0	49.5	43.5	36.6	19.5	-	-	
CVM AM 12	CVM A 12	0.9 + 0.9	12.4	5.4	75.0	69.5	65.0	59.5	52.5	44.0	23.4	-	-	
CVM AM 15	CVM A 15	1.1 + 1.1	14.6	6.6	87.5	80.5	75.5	69.5	61.0	51.0	27.3	-	-	
CVM AM 18	CVM A 18	1.3 + 1.3	15.6	6.2	103.0	94.5	88.0	80.0	70.0	58.5	28.8	-	-	
CVM BM 12	CVM B 12	0.9 + 0.9	11.6	5.4	51.0	-	48.0	47.0	45.0	42.5	36.6	28.8	19.6	
CVM BM 15	CVM B 15	1.1 + 1.1	14.6	6.8	63.5	-	60.5	58.5	56	53.5	46	36	24.5	
CVM BM 20	CVM B 20	1.5 + 1.5	12.8	6.6	78.5	-	74.0	72.0	69.0	85.5	56.0	44.5	30.6	
CVM BM 23	CVM B 23	1.7 + 1.7	19.2	8.6	91.5	-	86.0	84.0	80.5	76.5	65.5	51.5	35.7	
-	CVM B 25	1.8 + 1.8	-	8.6	105.0	-	98.5	96.0	92.0	87.0	74.5	59.0	41.0	

UNITS WITH 2 CLOSE-COUPLED HORIZONTAL DUAL-IMPELLER PUMPS WITH STAINLESS STEEL HYDRAULIC PARTS "2CDX" SERIES



*Tanks optional

TYPICAL APPLICATIONS

The unit's base plate is in galvanized steel, as are the manifolds. The delivery manifold is supplied ready to accommodate 2 vertical diaphragm tanks, where needed. It has 2 pressure switches, the control board and a pressure gauge fitted.

Each motor-driven pump has an isolating valve and a nonreturn valve on the suction line, with the option of connecting an air supplier, and features another isolating valve on the delivery.

PROTECTION AND CONTROL BOARD WITH CE MARK

- Components are IMQ and VDE certified.
- Very low voltage auxiliary circuit.
- Motors are switched on and off by two pressure switches.
- Float switches, or a low-limit pressure switch, can be connected to prevent operation when there is no water for suction.
- There is a device alternating the order pumps come on every time they are started.
- Power supply: - single-phase 230 V, 50Hz
- three-phase 400 V, 50Hz.
- Starting: - direct.
- Fuses protecting power circuit.
- Fuses protecting auxiliary circuit.
- IP rating IP 55.
- Master line disconnecter with door lock.
- Auto - 0 - Hand switches for each pump.
- Thermal overload cutout reset.
- Indicator LED: - mains power
- motor running
- level alarm
- motor cutout tripped
(for three-phase version only).
- Output provided for alarm warning.
- Special-version boards can be used on request.

THEORY OF OPERATION

If water is taken from the system, or leaks, with the pumps stopped, pressure drops and the contact of the pressure switch with the highest setting consequently closes, causing the first motor-driven pump to start. If the flow out is higher than the capacity of one pump, pressure will continue to drop until it causes the contact of the second pressure switch to close and hence the second pump to start. When delivery ends or the output flow is reduced, pressure in the system is raised, causing the contacts of the pressure switches to open and the pumps to stop in sequence. Reversing the order in which the two motors come on reduces the number of times the individual pumps start per hour and evens out pump operation. Connecting a float switch or minimum pressure switch to the control panel (both for drawing from the primary storage tank and from the water circuit) will prevent the most frequent cause of motor-driven pump failure: no water for suction



2GP 2CDX 70 PERFORMANCE CURVES (according to ISO 9906 Annex A)

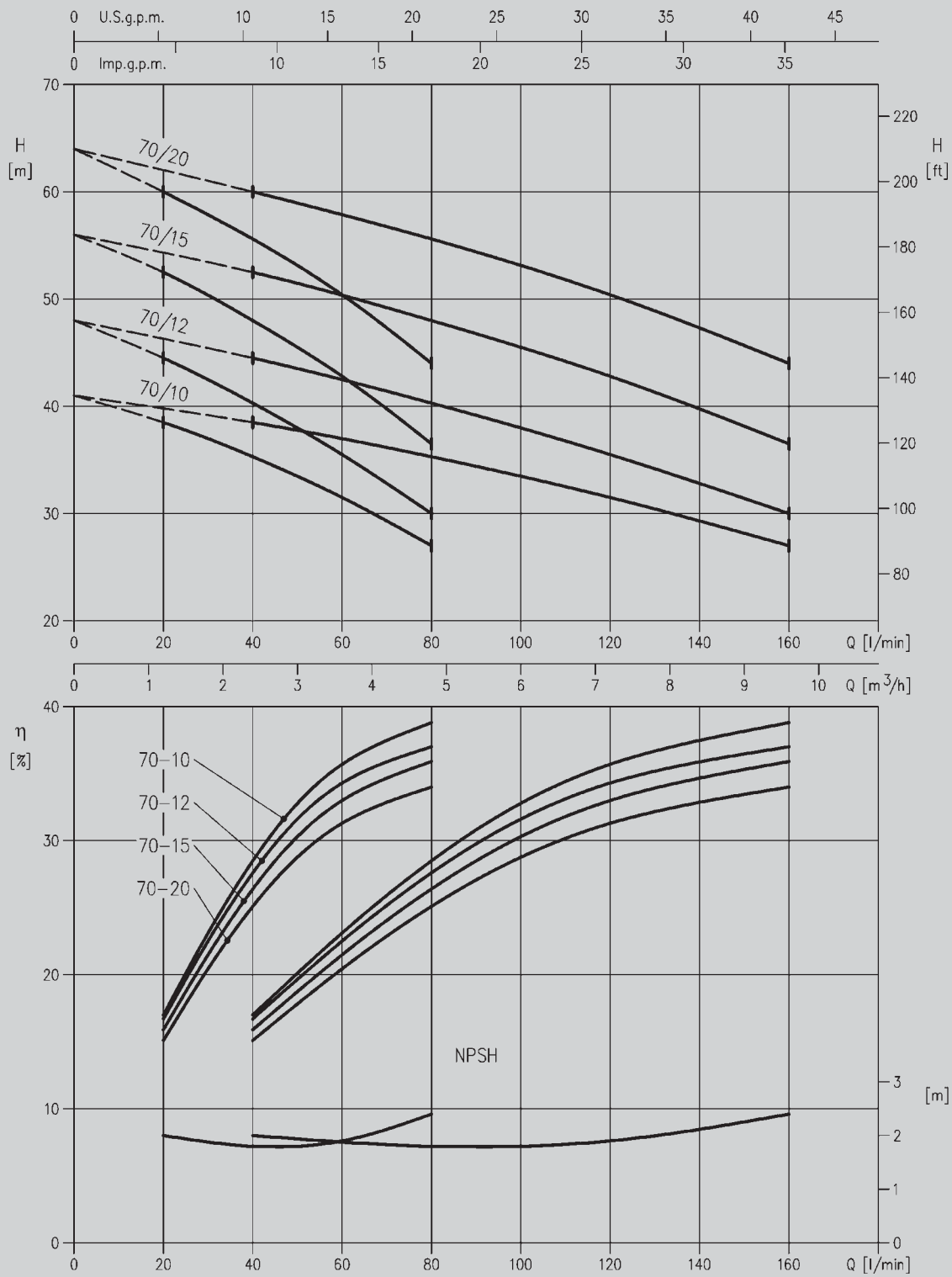

2GP 2CDX 120 PERFORMANCE CURVES (according to ISO 9906 Annex A)

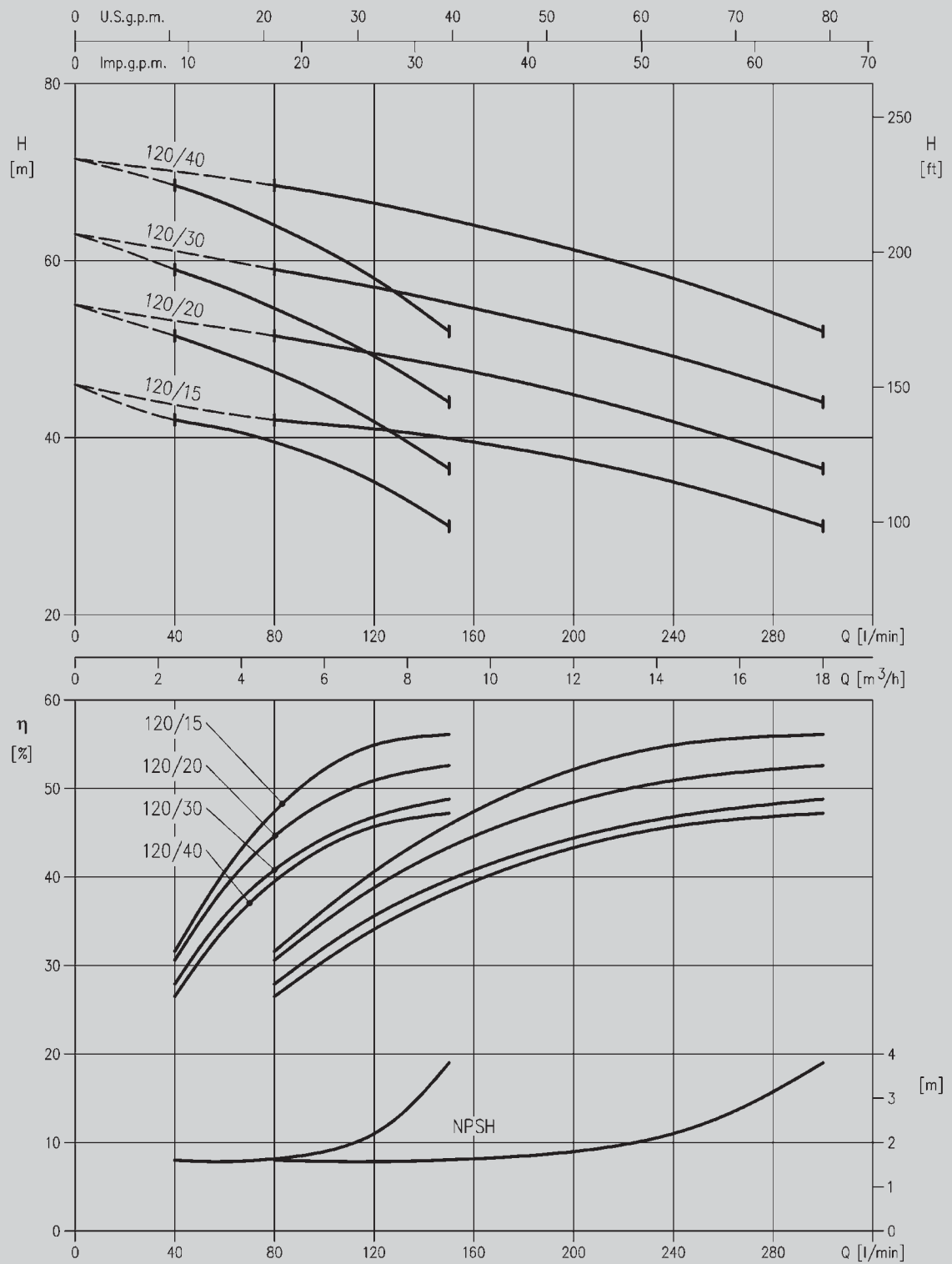

2GP 2CDX 200 PERFORMANCE CURVES (according to ISO 9906 Annex A)

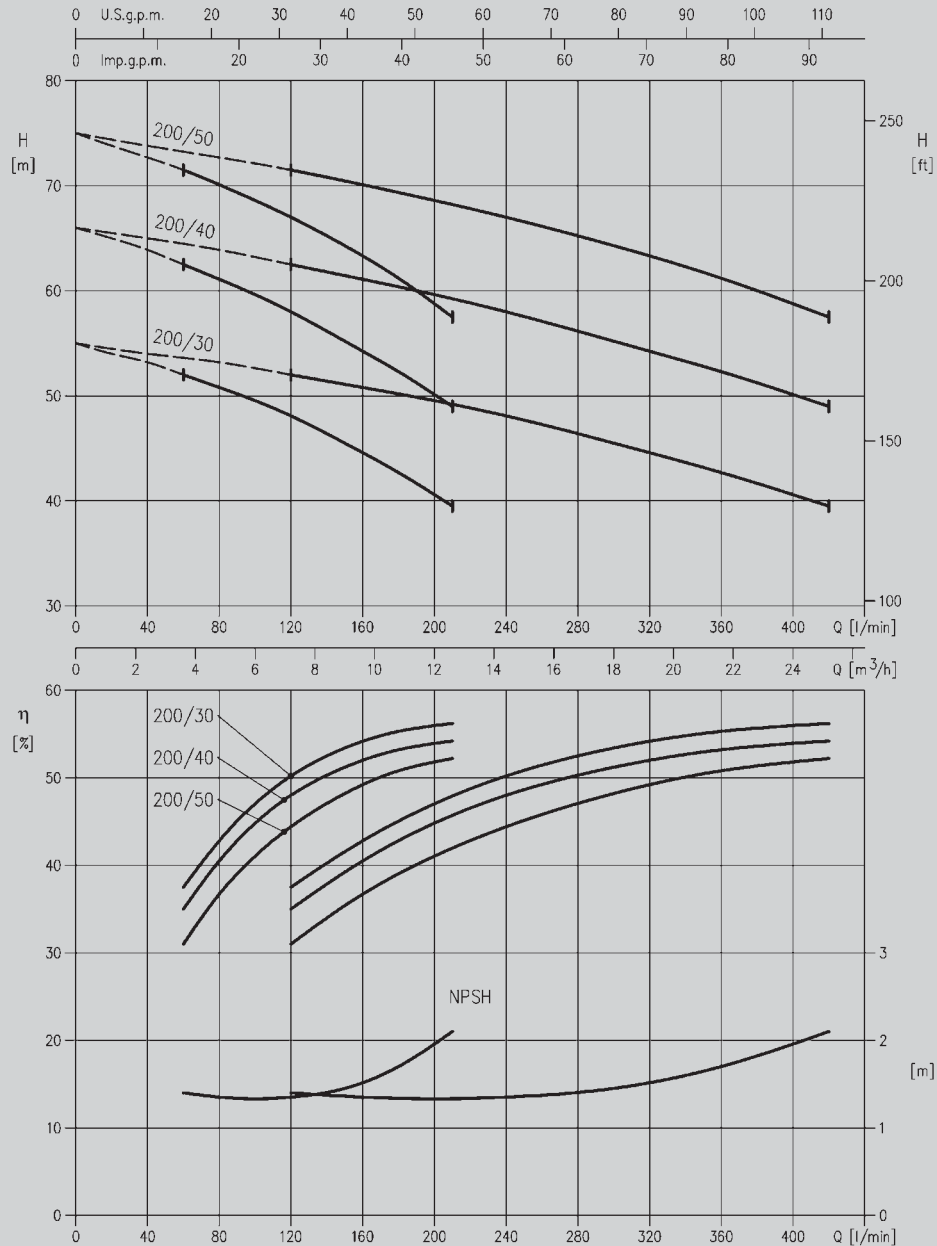

PERFORMANCE CHART FOR BOTH PUMPS WORKING AT THE SAME TIME

Type of pump		kW	Max. absorbed power (A)		Q=Flow rate											
Single-phase 230 V	Three-phase 400 V		Single-phase 230 V	Three-phase 400 V	l/min m³/h	0	40	80	120	160	200	240	300	360	420	
2CDXM 70/10	2CDX 70/10	0.75 + 0.75	12	4.6	0	2.4	4.8	7.2	9.6	12	14.4	18	21.6	25.2		
2CDXM 70/12	2CDX 70/12	0.9 + 0.9	14	5.8	41	38.5	35.0	31.5	27.0							
2CDXM 70/15	2CDX 70/15	1.1 + 1.1	16.2	6.6	48	44.5	40.3	35.2	29.0							
2CDXM 70/20	2CDX 70/20	1.5 + 1.5	20	8	56	52.5	48.0	42.8	36.5							
2CDXM 120/15	2CDX 120/15	1.1 + 1.1	16.6	6.6	64	60.0	55.6	50.0	44.0							
2CDXM 120/20	2CDX 120/20	1.5 + 1.5	20.4	8	46		42.0	41.5	39.5	37.5	35.0	30.0				
	2CDX 120/30	2.2 + 2.2		10	55		51.5	49.5	47.0	45	42.0	36.5				
	2CDX 120/40	3 + 3		12.4	63		59.0	57.0	54.6	52	49.0	44.0				
	2CDX 200/30	2.2 + 2.2		12	71.5		68.5	66.5	64.0	61	57.5	52.0				
	2CDX 200/40	3 + 3		13.2	55			52.0	51.0	49.5	48.0	45.5	42.6	39.5		
	2CDX 200/50	3.7 + 3.7		17.4	66			62.5	61.0	59.5	58.0	55.0	52.2	49.0		
					75			71.5	70.0	68.5	67.0	64.0	61.3	57.5		

DIMENSION DRAWINGS

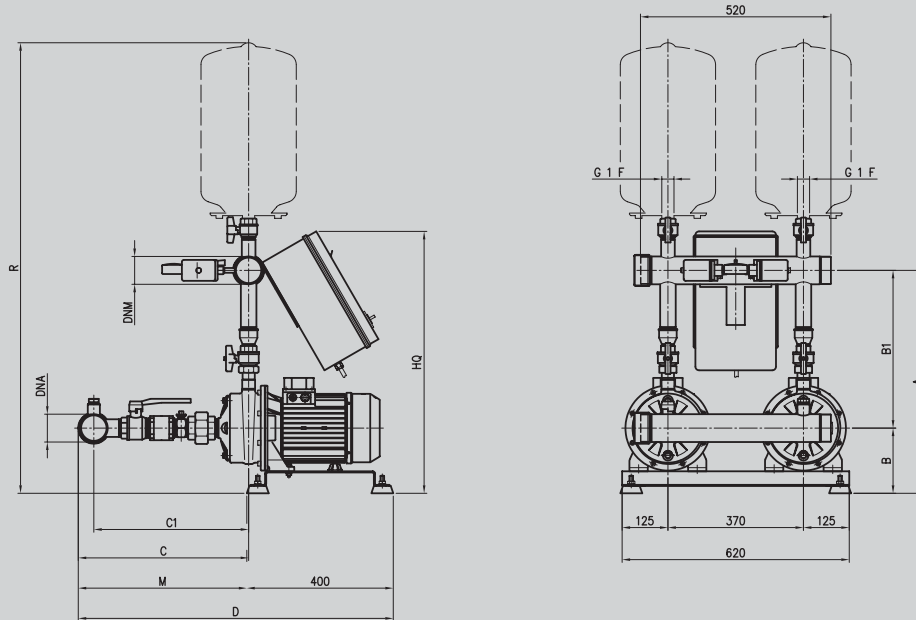

DIMENSION TABLE

Model	A		B	B1		C		C1		D		DNA	DNM	HQ		M		R		Weight (kg)	
	standard version	ANSI 304 version		standard version	ANSI 304 version	standard version	ANSI 304 version	standard version	ANSI 304 version	standard version	ANSI 304 version			standard version	ANSI 304 version	standard version	ANSI 304 version	standard version	ANSI 304 version	standard version	ANSI 304 version
2GP 2CDX 70/10	525	620	165	360	455	420	530	385	495	800	910	G 2	G 1½	625	720	400	510	1130	1280	53	54
2GP 2CDX 70/12														54	55						
2GP 2CDX 70/15	550	645	180	370	465	485	635	445	595	880	1030	G 2½	G 2	650	745	400	510	1155	1300	60	61
2GP 2CDX 70/20														64	65						
2GP 2CDX 120/15	535	630	165	370	465	485	635	445	595	880	1030	G 2½	G 2	635	730	465	615	1145	1295	60	61
2GP 2CDX 120/20														63	64						
2GP 2CDX 120/30	555	650	180	375	470	485	635	445	595	880	1030	G 2½	G 2	685	750	480	630	1165	1315	76	77
2GP 2CDX 120/40														83	84						
2GP 2CDX 200/30	585	715	165	420	550	465	605	425	560	860	1000	G 2½	G 2½	690	820	460	600	1205	1385	80	81
2GP 2CDX 200/40														715	845					1230	1410
2GP 2CDX 200/50	610	740	180	430	560	465	605	425	560	860	1000	G 2½	G 2½	715	845	460	600	1230	1410	95	96

UNITS WITH 2 CLOSE-COUPLED HORIZONTAL SINGLE/DUAL-IMPELLER PUMPS WITH CAST IRON HYDRAULIC PARTS, "CMA-CMB-CDA" SERIES



*Tanks optional

TYPICAL APPLICATIONS

The unit's base plate is in galvanized steel, as are the manifolds. The delivery manifold is supplied ready to accommodate 2 vertical diaphragm tanks, where needed. It has 2 pressure switches, the control board and a pressure gauge fitted.

Each motor-driven pump has an isolating valve and a nonreturn valve on the suction line, with the option of connecting an air supplier, and features another isolating valve on the delivery.

PROTECTION AND CONTROL BOARD WITH CE MARK

- Components are IMQ and VDE certified.
- Very low voltage auxiliary circuit.
- Motors are switched on and off by two pressure switches.
- Float switches, or a low-limit pressure switch, can be connected to prevent operation when there is no water for suction.
- There is a device alternating the order pumps come on every time they are started.
- Power supply: - single-phase 230 V, 50Hz
- three-phase 400 V, 50Hz.
- Starting: - direct.
- Fuses protecting power circuit.
- Fuses protecting auxiliary circuit.
- IP rating IP 55.
- Master line disconnecter with door lock.
- Auto - 0 - Hand switches for each pump.
- Thermal overload cutout reset.
- Indicator LED: - mains power
- motor running
- level alarm
- motor cutout tripped
(for three-phase version only).
- Output provided for alarm warning.
- Special-version boards can be used on request.

THEORY OF OPERATION

If water is taken from the system, or leaks, with the pumps stopped, pressure drops and the contact of the pressure switch with the highest setting consequently closes, causing the first motor-driven pump to start. If the flow out is higher than the capacity of one pump, pressure will continue to drop until it causes the contact of the second pressure switch to close and hence the second pump to start. When delivery ends or the output flow is reduced, pressure in the system is raised, causing the contacts of the pressure switches to open and the pumps to stop in sequence. Reversing the order in which the two motors come on reduces the number of times the individual pumps start per hour and evens out pump operation. Connecting a float switch or minimum pressure switch to the control panel (both for drawing from the primary storage tank and from the water circuit) will prevent the most frequent cause of motor-driven pump failure: no water for suction

2GP CMA PERFORMANCE CURVES (according to ISO 9906 Annex A)

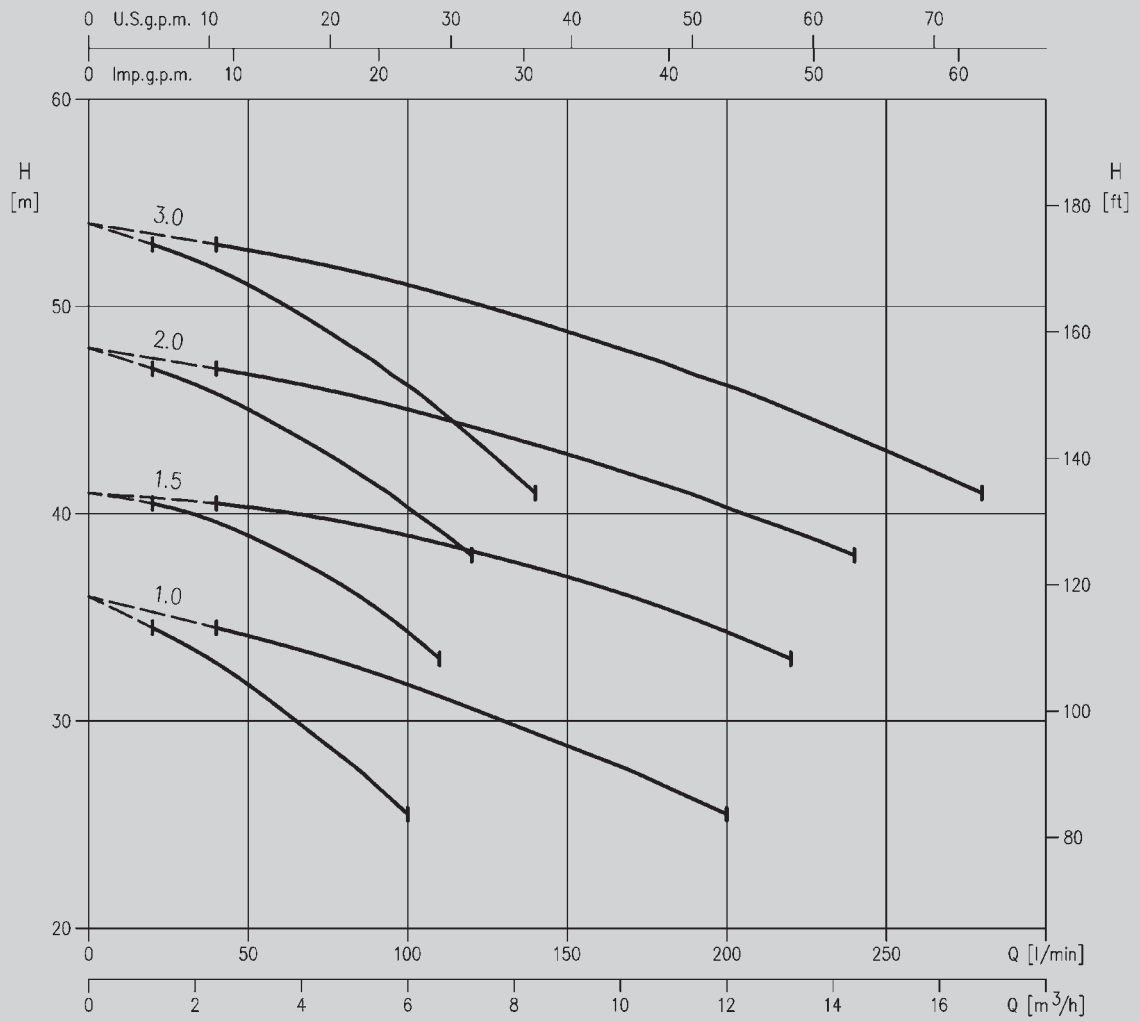



2GP CMB PERFORMANCE CURVES (according to ISO 9906 Annex A)

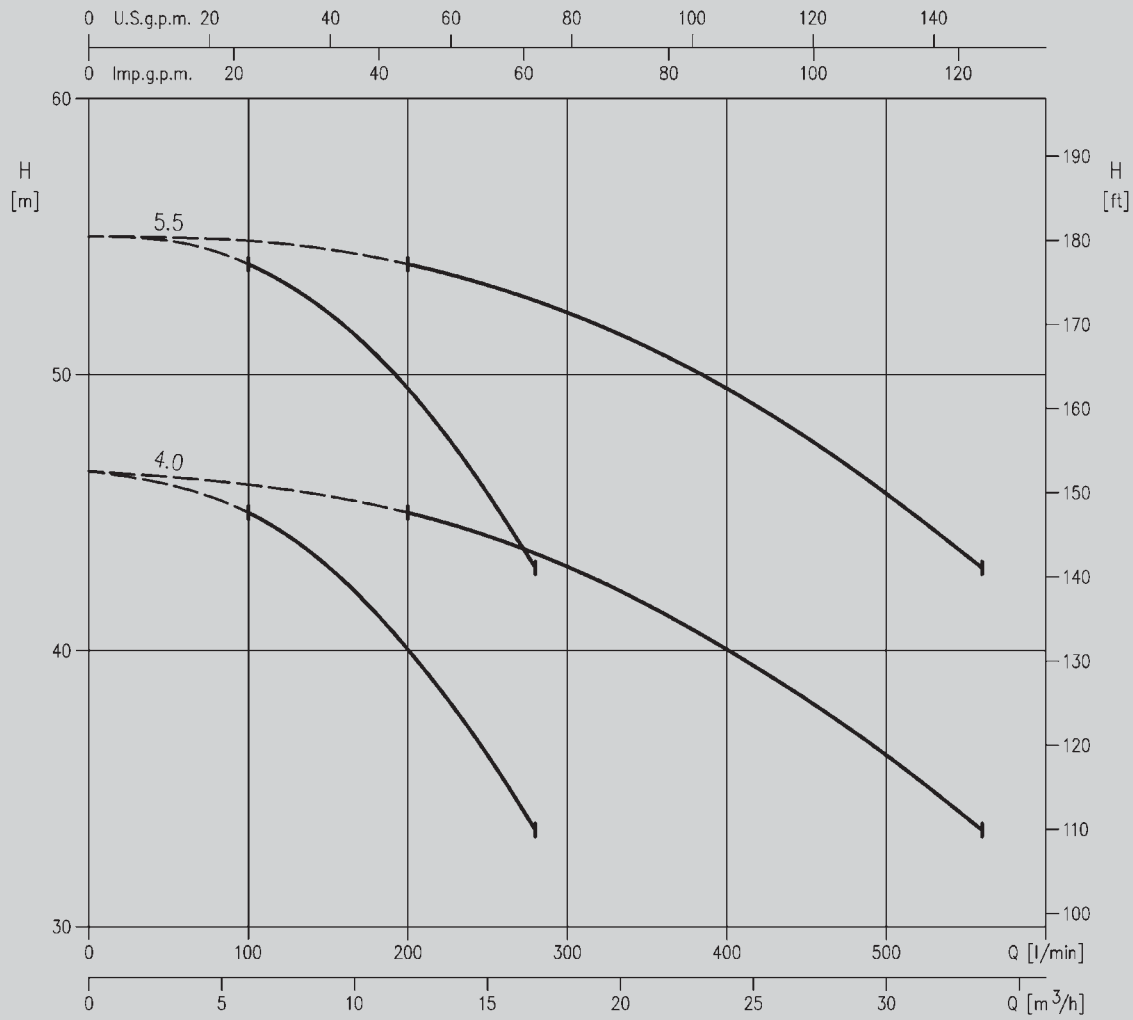

2GP CDA PERFORMANCE CURVES (according to ISO 9906 Annex A)

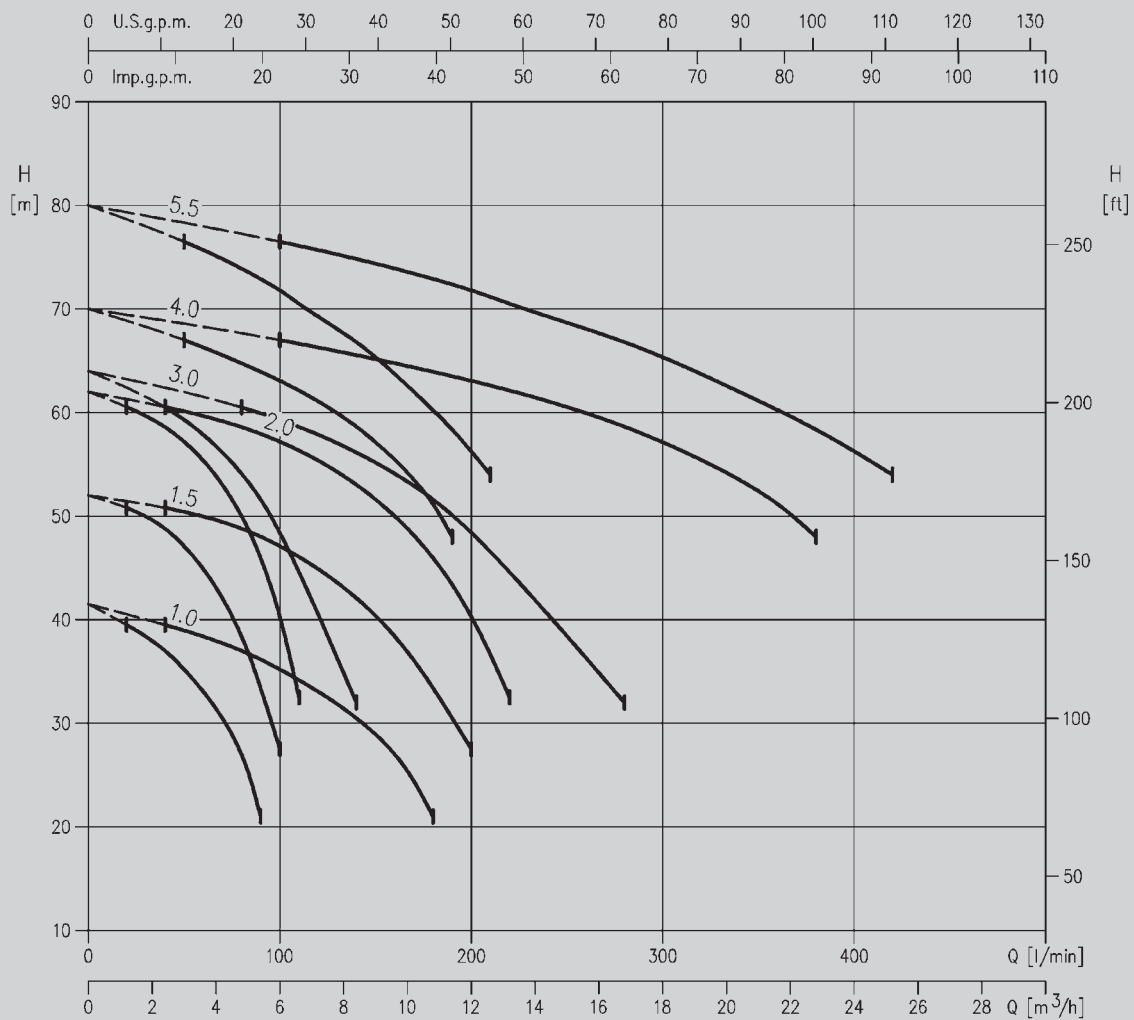

PERFORMANCE CHART FOR BOTH PUMPS WORKING AT THE SAME TIME

Type of pump		kW	Max absorbed power (A)		Q=Flow rate																	
Single-phase 230 V	Three-phase 400 V		Single-phase 230 V	Three-phase 400 V	l/min	0	40	80	100	160	180	200	220	240	280	380	420	500	560			
						m³/h	0	2,4	4,8	8	9,6	10,8	12	13,2	14,4	16,8	22,8	25,2	30	33,6		
						H = Discharge head in mwc																
CMA 1,00M	CMA 1,00T	0,75 + 0,75	12,4	5	36,0	34,5	32,8	31,8	28,2	26,9	25,5	-	-	-	-	-	-	-	-	-	-	
CMA 1,50M	CMA 1,50T	1,1 + 1,1	16	6,2	41,0	40,5	39,6	39,0	36,5	35,6	34,3	33,0	-	-	-	-	-	-	-	-	-	
CMA 2,00M	CMA 2,00T	1,5 + 1,5	20,6	8,6	48,0	47,0	46,0	45,0	42,5	41,5	40,5	39,2	38,0	-	-	-	-	-	-	-	-	
	CMA 3,00T	2,2 + 2,2		11	54,0	53,0	52,0	51,0	48,5	47,5	46,0	45,0	43,5	41,0	-	-	-	-	-	-	-	
	CMB 4,00T	3 + 3		13,8	46,5	-	-	-	-	-	45,0	44,5	44,0	43,5	41,0	39,4	36,2	33,5				
	CMB 5,50T	4 + 4		18,4	55,0	-	-	-	-	-	54,0	53,5	53,0	52,5	50,0	49,0	45,5	43,0				
CDA 1,00M	CDA 1,00T	0,75 + 0,75	12,2	4,6	41,5	39,5	37,0	35,2	27,0	21,0	-	-	-	-	-	-	-	-	-	-	-	
CDA 1,50M	CDA 1,50T	1,1 + 1,1	18	6,8	52,0	50,8	49,0	47,0	38,4	33,4	27,5	-	-	-	-	-	-	-	-	-	-	
CDA 2,00M	CDA 2,00T	1,5 + 1,5	21,6	8,6	62,0	60,5	58,5	57,0	50,0	46,5	40,5	32,5	-	-	-	-	-	-	-	-	-	
	CDA 3,00T	2,2 + 2,2		10,2	64,0	-	60,5	59,5	54,0	51,5	48,5	44,5	40,5	32,0	-	-	-	-	-	-	-	
	CDA 4,00T	3 + 3		15	70,0	-	-	67,0	65,0	64,0	62,5	62,0	61,0	58,0	48,0	-	-	-	-	-	-	
	CDA 5,50T	4 + 4		19	80,0	-	-	76,5	74,0	73,0	72,0	70,5	69,0	67,0	58,5	54,0	-	-	-	-	-	

DIMENSION DRAWINGS

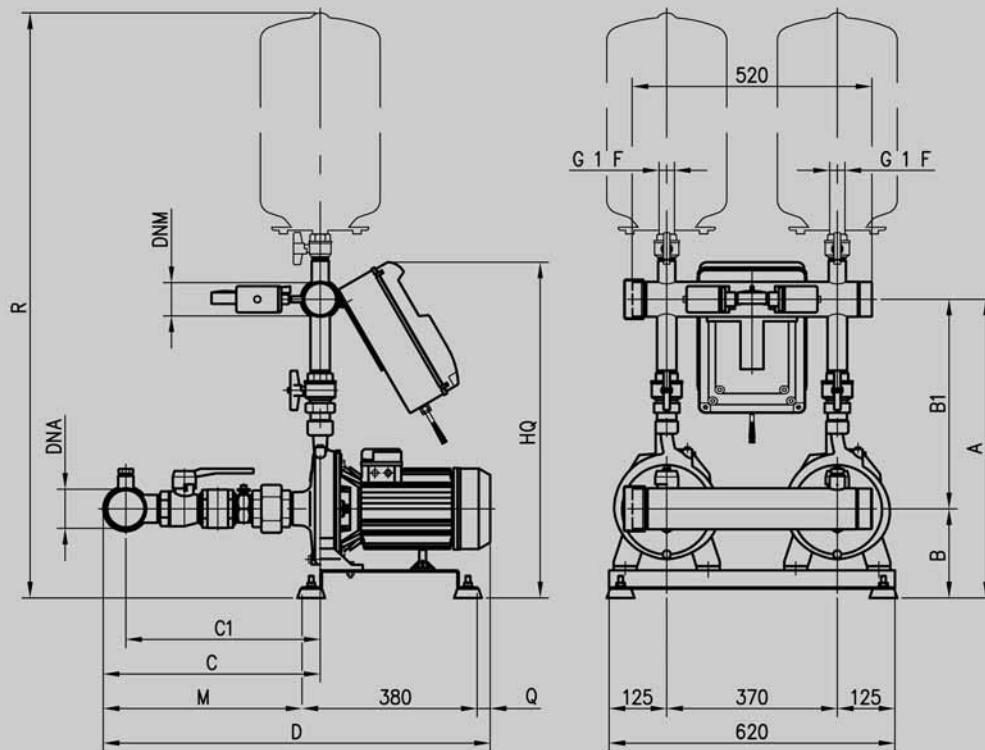

DIMENSION TABLE

Model	Dimensions (mm)												
	A	B	B1	C	C1	D	DNA	DNM	HQ	M	Q	R	Weight (kg)
2GP CMA 100	540	155	385	400	365	710	G2	G2	615	330	-	1150	60
2GP CMA 150	570	160	410	380	345	695	G2	G2	635	315	-	1170	72
2GP CMA 200	605	175	430	380	345	695	G2	G2	670	315	-	1205	76
2GP CMA 300	605	175	430	380	345	695	G2	G2	670	315	-	1205	78
2GP CMB 400	650	195	455	470	420	840	G3	G2 1/2	730	430	30	1270	127
2GP CMB 550	650	195	455	470	420	840	G3	G2 1/2	730	430	30	1270	131
2GP CDA 100	530	160	370	425	395	730	G2	G1 1/2	600	350	-	1135	66
2GP CDA 150	565	170	395	420	385	730	G2	G1 1/2	640	340	10	1170	90
2GP CDA 200	585	170	415	420	385	745	G2	G2	650	340	25	1185	94
2GP CDA 300	625	170	455	490	445	815	G2 1/2	G2 1/2	705	405	30	1245	98
2GP CDA 400	635	195	440	475	430	845	G2 1/2	G2 1/2	715	390	75	1255	130
2GP CDA 550	635	195	440	475	430	845	G2 1/2	G2 1/2	715	390	75	1255	138

UNITS WITH 2 CLOSE-COUPLED VERTICAL MULTISTAGE WATER JACKET COOLED PUMPS "MULTIGO" SERIES



*Tanks optional

TYPICAL APPLICATIONS

The unit's base plate is in galvanized steel, as are the manifolds. The delivery manifold is supplied ready to accommodate 2 vertical diaphragm tanks, where needed. It has 2 pressure switches, the control board and a pressure gauge fitted.

Each motor-driven pump has an isolating valve and a nonreturn valve on the suction line, with the option of connecting an air supplier, and features another isolating valve on the delivery.

PROTECTION AND CONTROL BOARD WITH CE MARK

- Components are IMQ and VDE certified.
- Very low voltage auxiliary circuit.
- Motors are switched on and off by two pressure switches.
- Float switches, or a low-limit pressure switch, can be connected to prevent operation when there is no water for suction.
- There is a device alternating the order pumps come on every time they are started.
- Power supply:
 - single-phase 230 V, 50Hz
 - three-phase 400 V, 50Hz.
- Starting:
 - direct.
- Fuses protecting power circuit.
- Fuses protecting auxiliary circuit.
- IP rating IP 55.
- Master line disconnecter with door lock.
- Auto - 0 - Hand switches for each pump.
- Thermal overload cutout reset.
- Indicator LED:
 - mains power
 - motor running
 - level alarm
 - motor cutout tripped (for three-phase version only).
- Output provided for alarm warning.
- Special-version boards can be used on request.

THEORY OF OPERATION

If water is taken from the system, or leaks, with the pumps stopped, pressure drops and the contact of the pressure switch with the highest setting consequently closes, causing the first motor-driven pump to start. If the flow out is higher than the capacity of one pump, pressure will continue to drop until it causes the contact of the second pressure switch to close and hence the second pump to start. When delivery ends or the output flow is reduced, pressure in the system is raised, causing the contacts of the pressure switches to open and the pumps to stop in sequence. Reversing the order in which the two motors come on reduces the number of times the individual pumps start per hour and ensures both are used. Connecting a float switch or minimum pressure switch to the control panel (both for drawing from the primary storage tank and from the water circuit) will prevent the most frequent cause of motor-driven pump failure: no water for suction

2GP MULTIGO 40 / 80 PERFORMANCE CURVES (according to ISO 9906 Annex A)

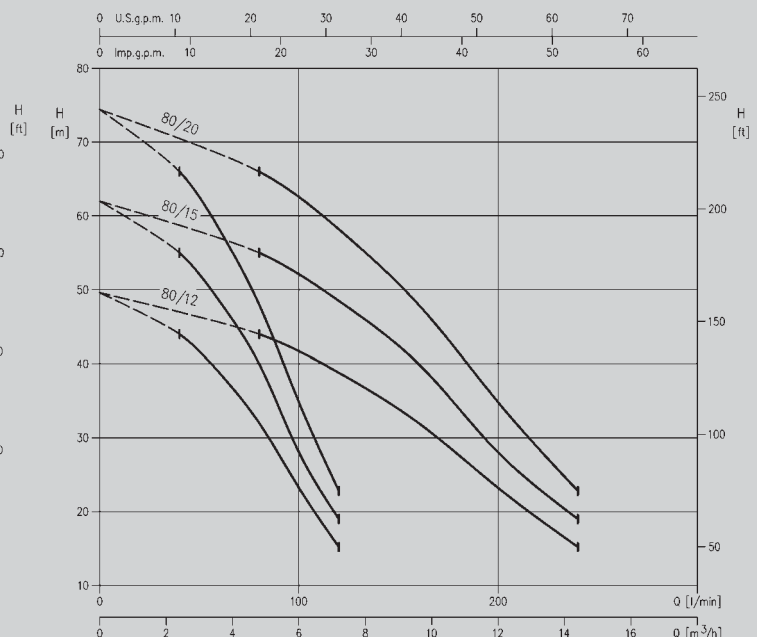
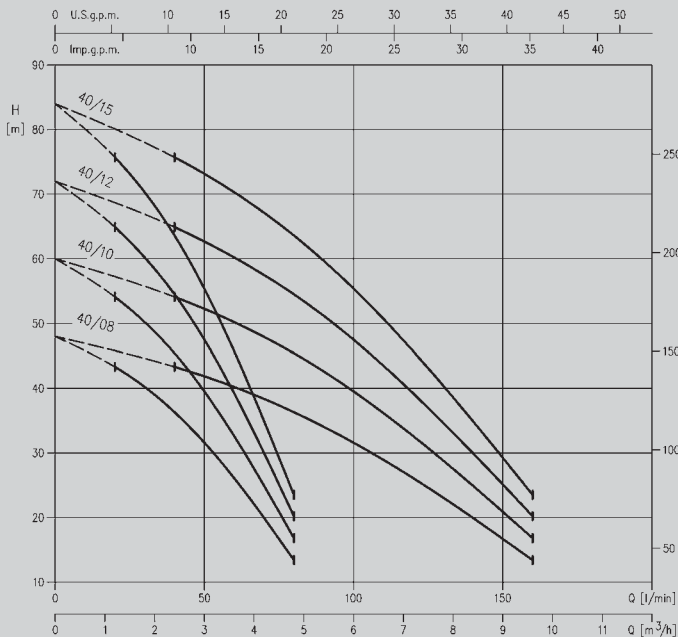

PERFORMANCE CHART FOR BOTH PUMPS WORKING AT THE SAME TIME

Type of pump		kW	Max. absorbed power (A)		Q=Flow rate							
Single-phase 230 V	Three-phase 400 V		Single-phase 230 V	Three-phase 400 V	l/min m³/h	0	40	80	120	160	200	240
Multigo M40/08	Multigo 40/08	0.6 + 0.6	8.6	3.8	0	2.4	4.8	7.2	9.6	12	14.4	
Multigo M40/10	Multigo 40/10	0.75 + 0.75	11.4	4.4	H = Discharge head in mwc							
Multigo M40/12	Multigo 40/12	0.88 + 0.88	13.6	4.8	48	43.3	36.3	26.1	13.4			
Multigo M40/15	Multigo 40/15	1.1 + 1.1	14.6	6	60	54.1	45.4	32.6	16.8			
Multigo M80/12	Multigo 80/12	0.88 + 0.88	12.8	4.6	72	64.9	54.5	39.2	20.2			
Multigo M80/15	Multigo 80/15	1.1 + 1.1	15	6.2	84	75.7	63.6	45.7	23.5			
	Multigo 80/20	1.5 + 1.5		7	49.6		44.0	38.8	32.0	23.2	15.2	
					62		55.0	48.5	40.0	28.0	19.0	
					74.4		66.0	58.2	48.0	34.8	22.8	

DIMENSION DRAWINGS

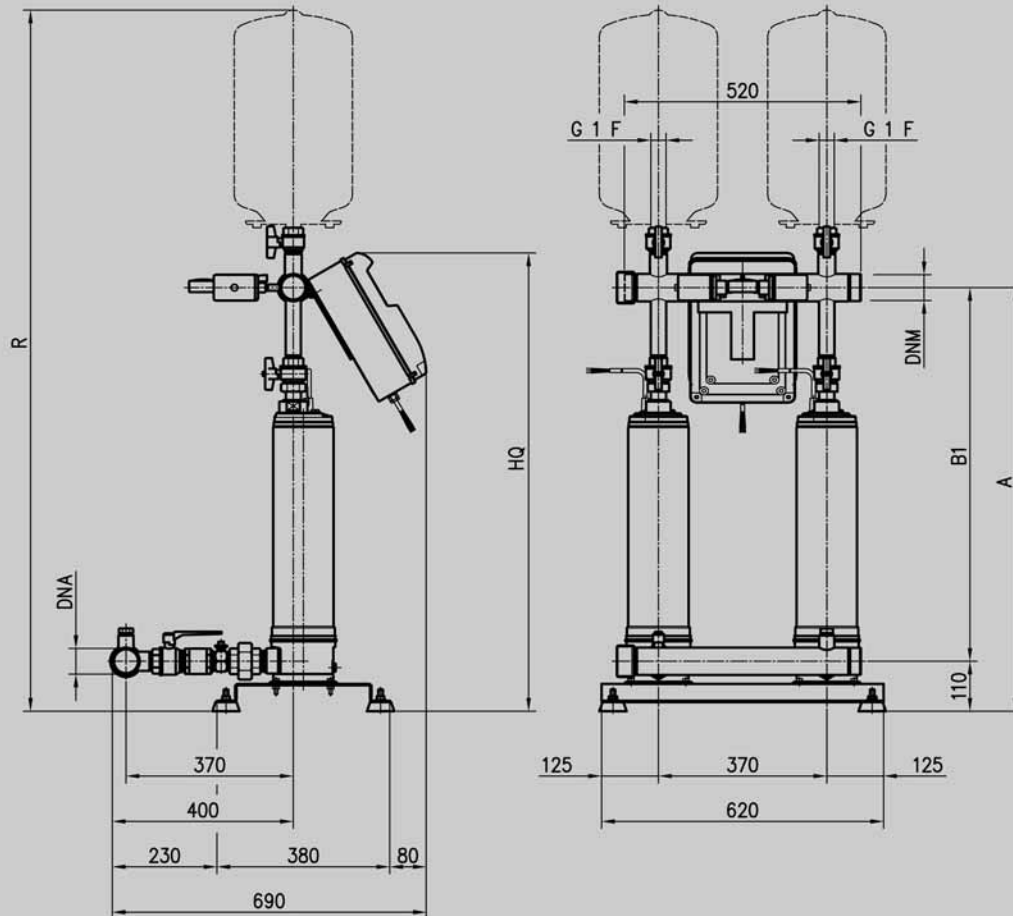

DIMENSION TABLE

Model	Dimensions (mm)						
	A	B1	HQ	R	DNA	DNM	Weight kg
2GP MULTIGO (M)40/08	855	745	930	1470	G2	G2	63
2GP MULTIGO (M)40/10	880	770	960	1495	G2	G2	65
2GP MULTIGO (M)40/12	930	820	1010	1545	G2	G2	66
2GP MULTIGO (M)40/15	960	850	1035	1570	G2	G2	69
2GP MULTIGO (M)80/12	880	770	960	1495	G2	G2	66
2GP MULTIGO (M)80/15	905	795	985	1520	G2	G2	68
2GP MULTIGO 80/20	930	820	1010	1545	G2	G2	70

UNITS WITH 2 VERTICAL MULTISTAGE PUMPS WITH ALL-STAINLESS-STEEL HYDRAULIC PARTS, "EVM" SERIES; OR WITH STAINLESS STEEL HYDRAULIC PARTS, LOWER CASING AND SEAL PLATE IN CAST IRON, "EVMG" SERIES WITH STANDARDIZED MOTOR



TYPICAL APPLICATIONS

The unit's base plate is in galvanized steel, as are the manifolds. The delivery manifold is supplied ready to accommodate 2 vertical diaphragm tanks, where needed. It has 2 pressure switches, the control board and a pressure gauge fitted. Each motor-driven pump has an isolating valve and a nonreturn valve on the suction line, with the option of connecting an air supplier, and features another isolating valve on the delivery. The control panel is supported by a special mount fastened to the base plate.

PROTECTION AND CONTROL BOARD WITH CE MARK

- Components are IMQ and VDE certified.
- Very low voltage auxiliary circuit.
- Motors are switched on and off by two pressure switches.
- Float switches, or a minimum pressure switch, can be connected to prevent operation when there is no water in suction line.
- There is a device alternating the order pumps come on every time they are started.
- Power supply:
 - single-phase 230 V, 50Hz
 - three-phase 400 V, 50Hz.
- Starting:
 - direct-on-line for wattages up to 7.5 kW
 - star-delta for wattages over 7.5 kW
- Fuses protecting power circuit.
- Fuses protecting auxiliary circuit.
- IP rating IP 55.
- Master line disconnecter with door lock.
- Auto - 0 - Hand switches for each pump.
- Thermal overload cutout reset.
- Indicator LED:
 - mains power
 - motor running
 - level alarm
 - motor cutout tripped (for three-phase version only).
- Output provided for alarm warning.
- Special-version boards can be used on request.

THEORY OF OPERATION

If water is taken from the system, or leaks, with the pumps stopped, pressure drops and the contact of the pressure switch with the highest setting consequently closes, causing the first motor-driven pump to start. If the flow out is higher than the capacity of one pump, pressure will continue to drop until it causes the contact of the second pressure switch to close and hence the second pump to start. When delivery ends or the output flow is reduced, pressure in the system is raised, causing the contacts of the pressure switches to open and the pumps to stop in sequence. Reversing the order in which the two motors come on reduces the number of times the individual pumps start per hour and ensures both are used. Connecting a float switch or minimum pressure switch to the control panel (both for drawing from the primary storage tank and from the water circuit) will prevent the most frequent cause of motor-driven pump failure: no water for suction

2GP EVM2 PERFORMANCE CURVES (according to ISO 9906 Annex A)

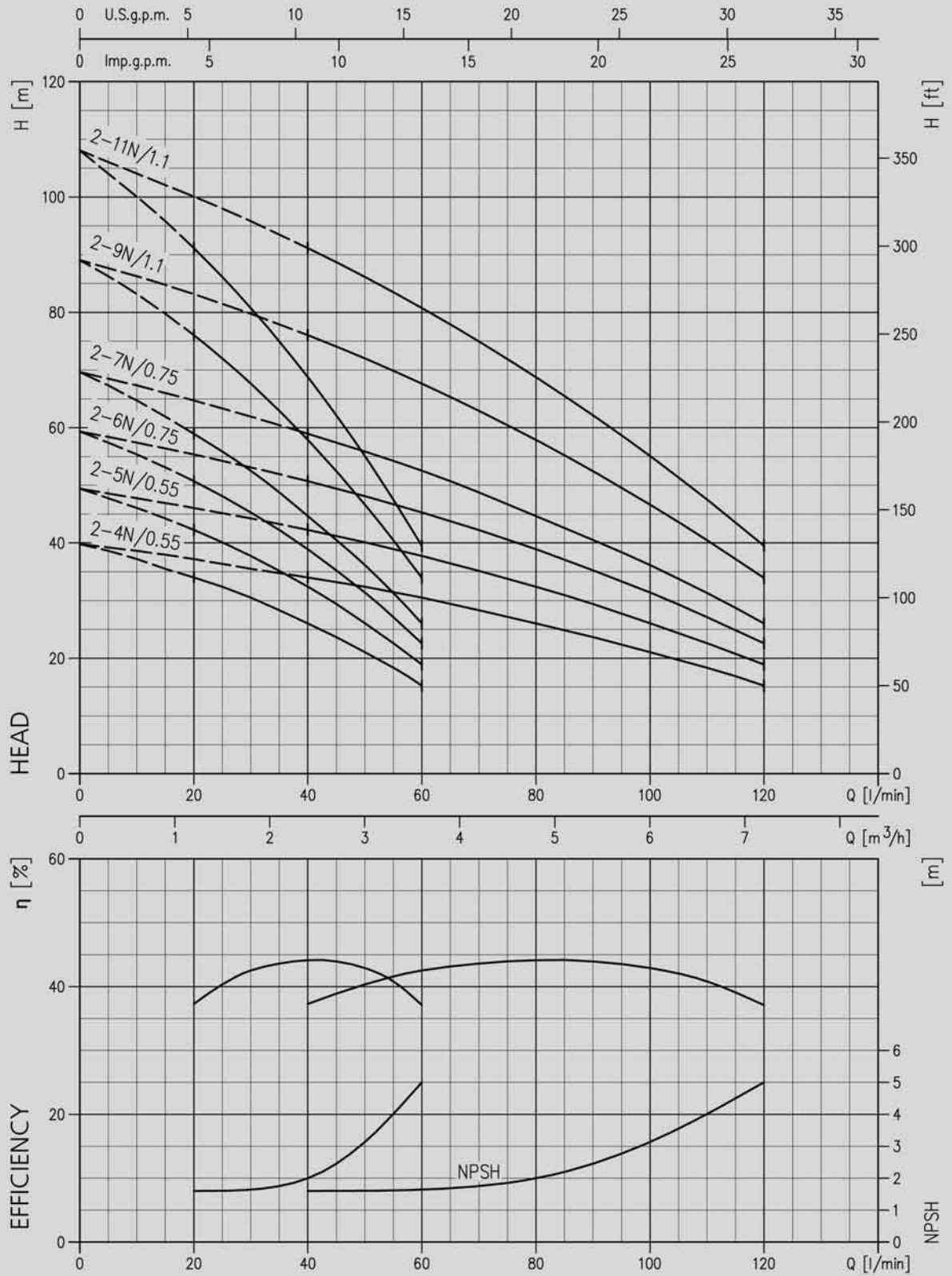

2GP EVM4 PERFORMANCE CURVES (according to ISO 9906 Annex A)

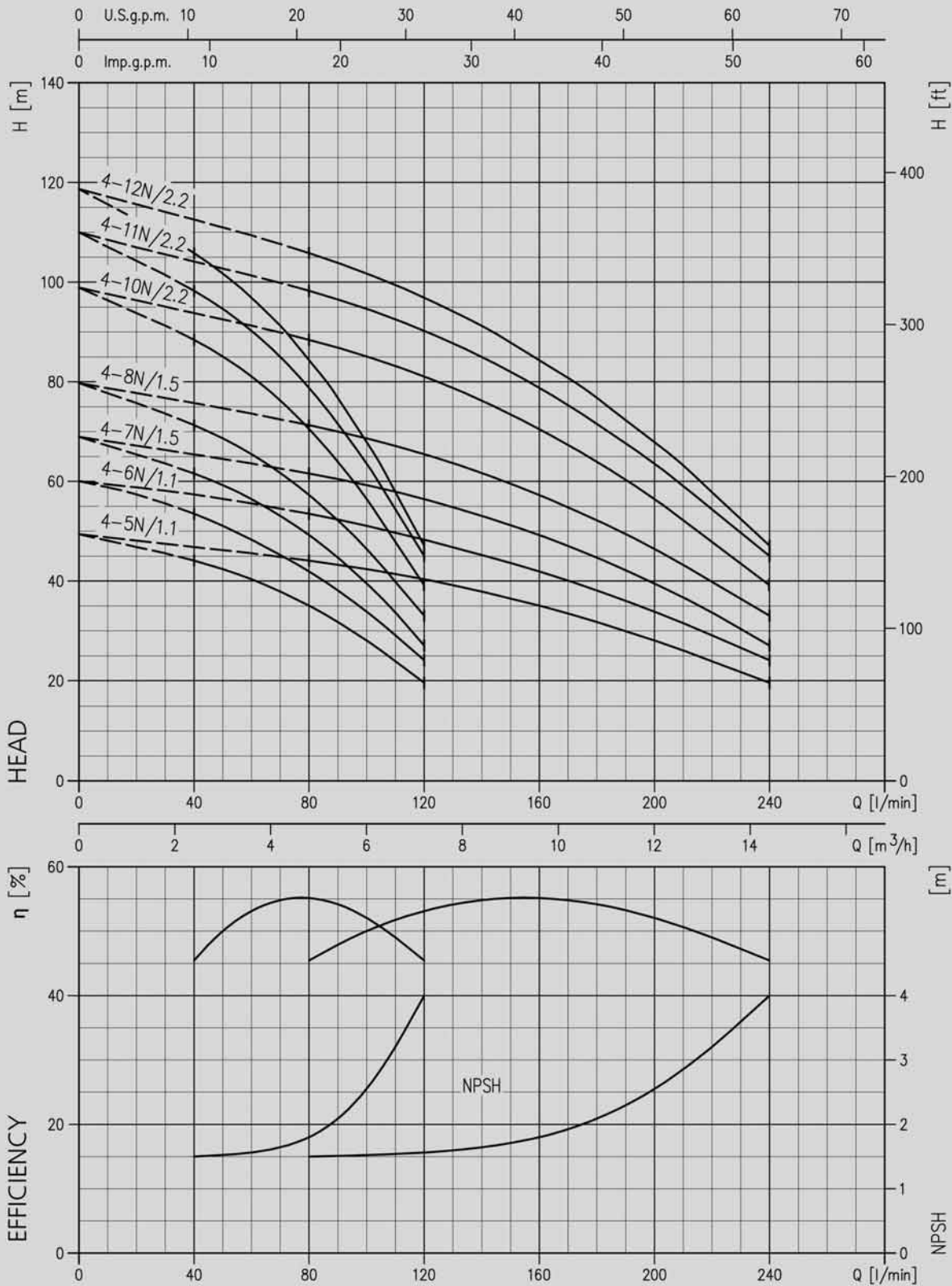

2GP EVM8 PERFORMANCE CURVES (according to ISO 9906 Annex A)

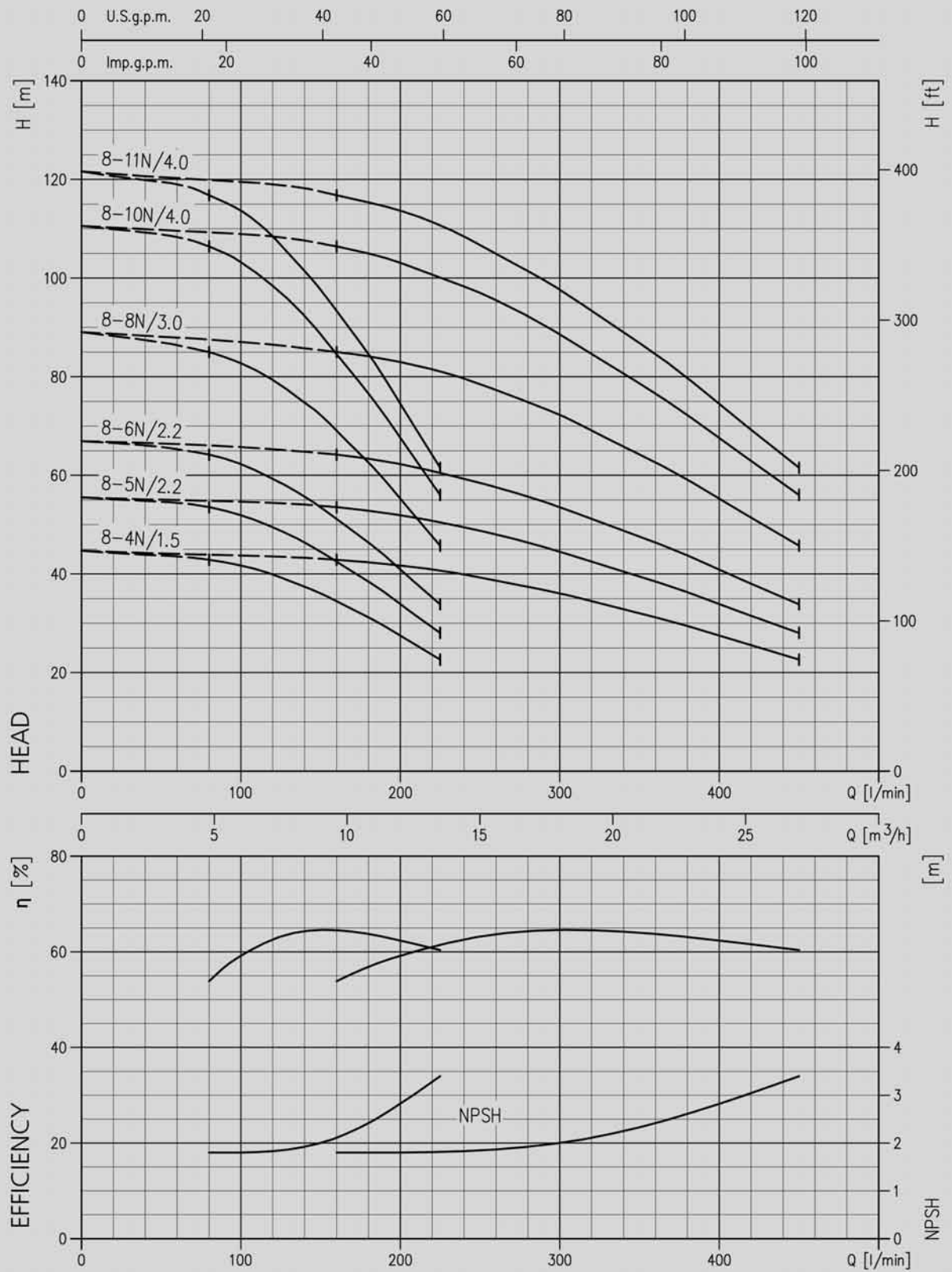



2GP EVM16 PERFORMANCE CURVES (according to ISO 9906 Annex A)

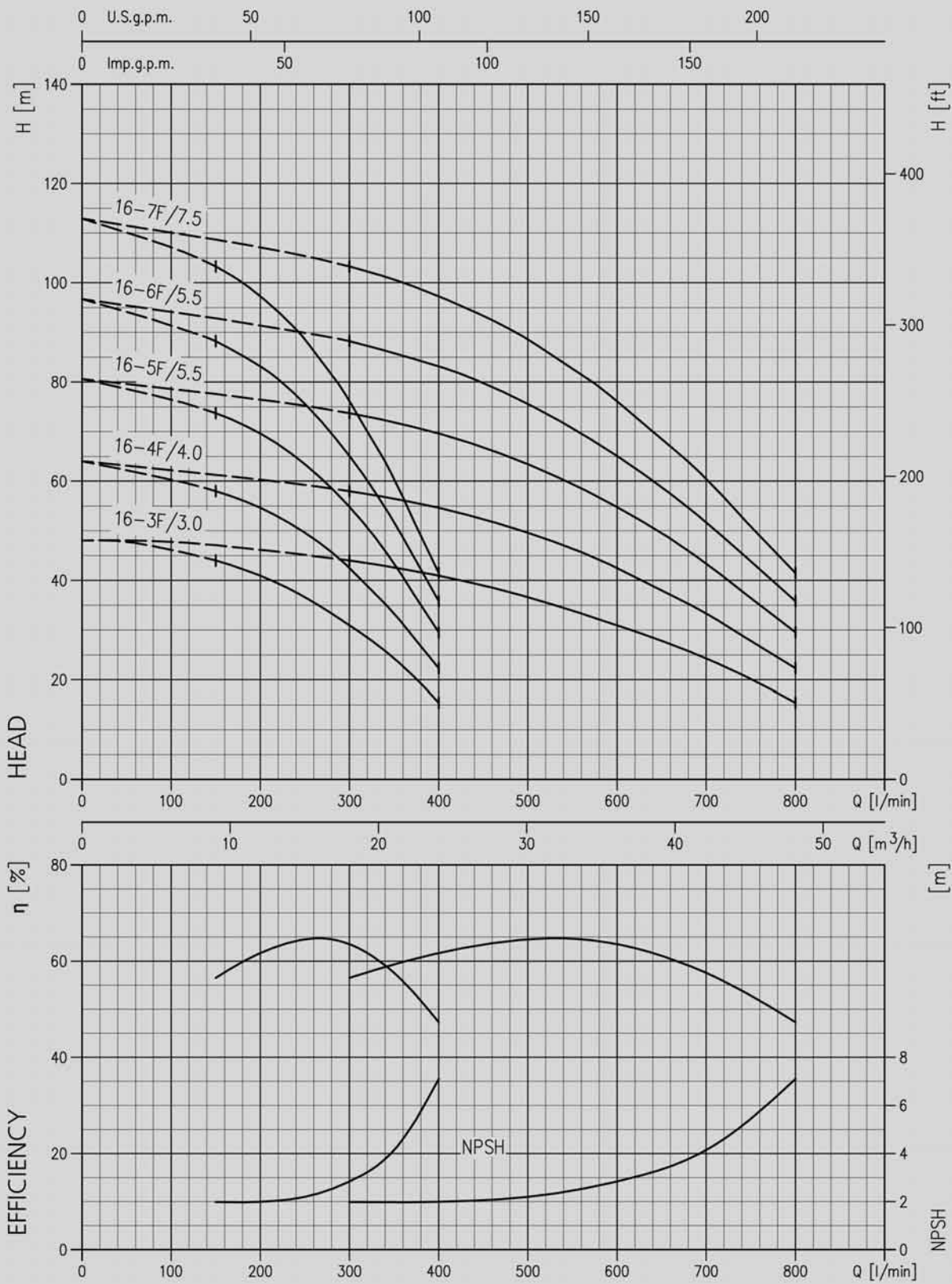

2GP EVM30 PERFORMANCE CURVES (according to ISO 9906 Annex A)

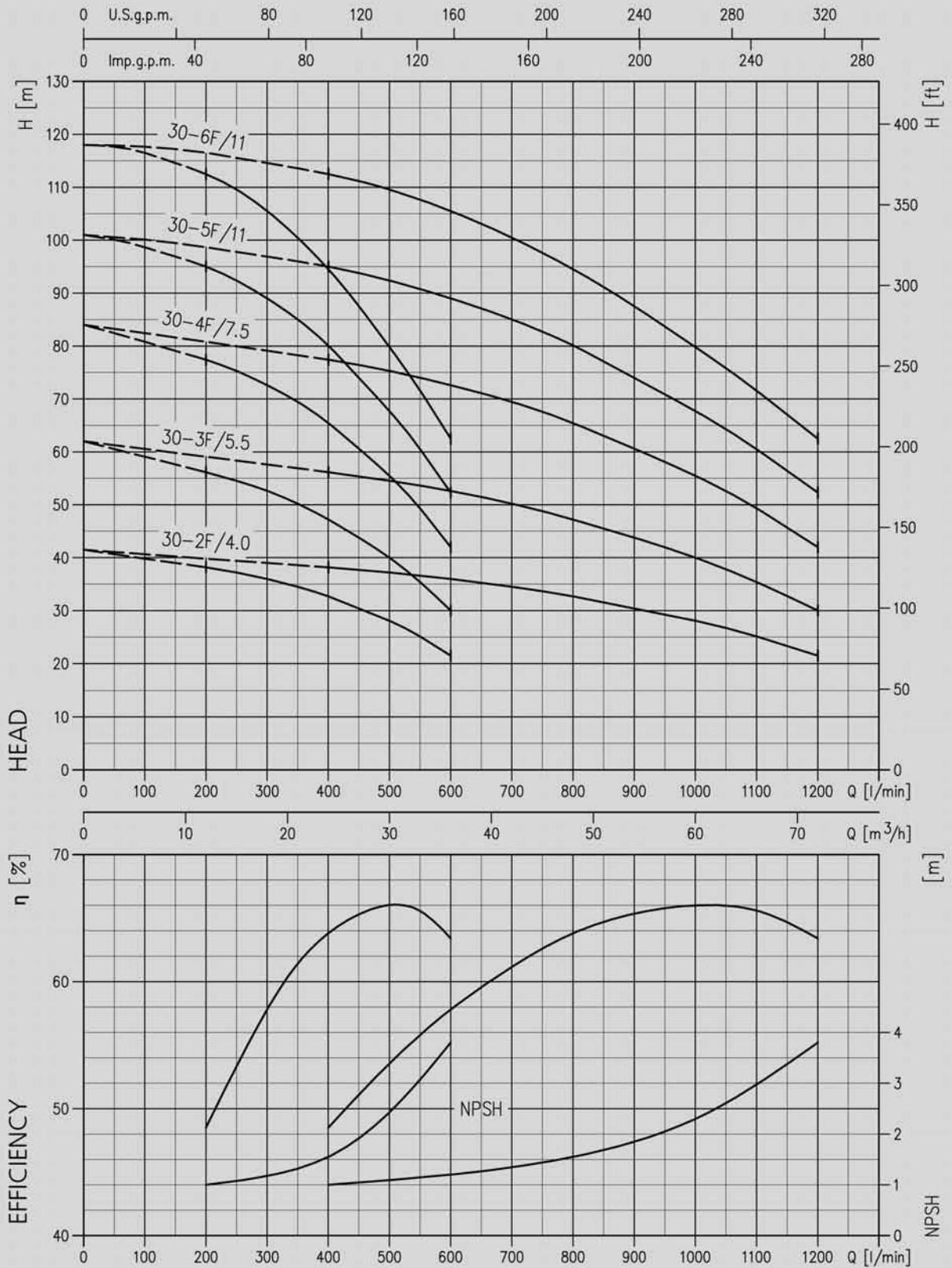

2GP EVM60 PERFORMANCE CURVES (according to ISO 9906 Annex A)

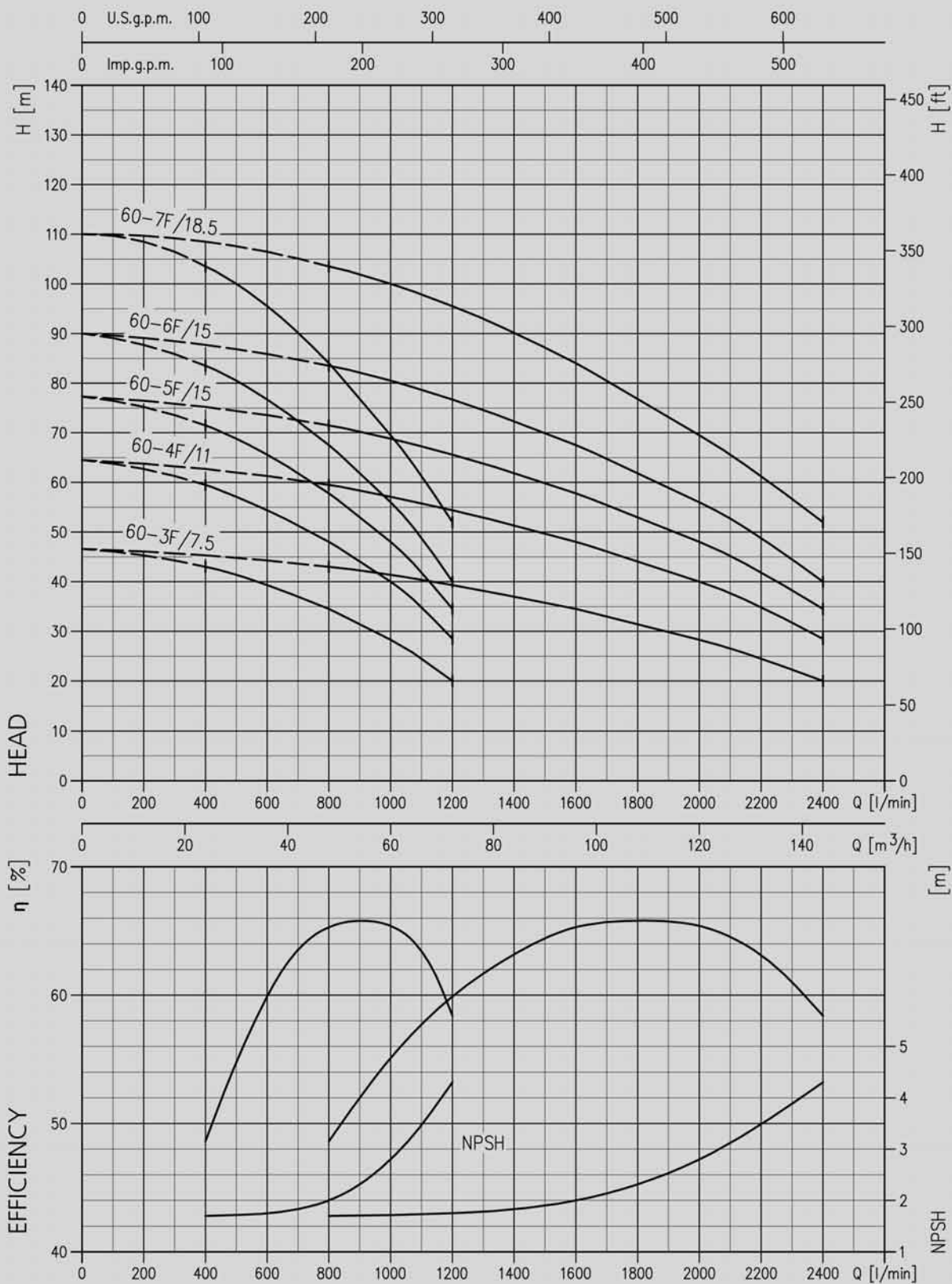

PERFORMANCE CHART FOR BOTH PUMPS WORKING AT THE SAME TIME

Type of pump		kW	Max absorbed power (A)		l/min m³/h	Q=Flow rate															
Single-phase 230 V	Three-phase 400 V		Single-phase 230 V	Three-phase 400 V		0	40	80	120	160	200	240	300	350	400	450	500	600	700	800	
						H = Discharge head in mwc															
EVM2 4N/0.55M	EVM2 4N/0.55	0.55 + 0.55	7.6	2.7	39.9	33.9	26.0	15.2													
EVM2 5N/0.55M	EVM2 5N/0.55	0.55 + 0.55	7.6	2.7	49.4	42.0	32.5	18.8													
EVM2 6N/0.75M	EVM2 6N/0.75	0.75 + 0.75	10.6	3.2	59.3	50.5	38.0	22.5													
EVM2 7N/0.75M	EVM2 7N/0.75	0.75 + 0.75	10.6	3.2	69.9	58.8	44.3	26.1													
EVM2 9N/1.1M	EVM2 9N/1.1	1.1 + 1.1	13	4.6	88.9	75.7	58.1	33.8													
EVM2 11N/1.1M	EVM2 11N/1.1	1.1 + 1.1	13	4.6	108.0	91.1	68.7	39.5													
EVM4 5N/1.1M	EVM4 5N/1.1	1.1 + 1.1	13	4.6	49.5		44.1	40.6	35.0	28.0	19.8										
EVM4 6N/1.1M	EVM4 6N/1.1	1.1 + 1.1	13	4.6	60.0		53.2	48.2	42.0	33.8	24.0										
EVM4 7N/1.5M	EVM4 7N/1.5	1.5 + 1.5	19	6.6	69.0		61.8	56.5	49.0	39.8	27.7										
EVM4 8N/1.5M	EVM4 8N/1.5	1.5 + 1.5	19	6.6	80.0		71.6	65.8	57.1	46.5	33.0										
	EVM4 10N/2.2	2.2 + 2.2		8.8	99.0		88.2	81.0	70.6	56.2	39.6										
	EVM4 11N/2.2	2.2 + 2.2		8.8	110.0		98.0	90.2	78.6	63.8	45.0										
	EVM4 12N/2.2	2.2 + 2.2		8.8	119.0		106.0	97.4	84.0	67.5	47.5										
EVM8 4N/1.5M	EVM8 4N/1.5	1.5 + 1.5		6.6	44.5				42.2	41.8	40.0	36.1	31.5	27.7	22.6						
	EVM8 5N/2.2	2.2 + 2.2		8.8	55.5				53.0	51.8	49.1	44.3	40.0	34.0	28.3						
	EVM8 6N/2.2	2.2 + 2.2		8.8	67.0				64.2	62.0	59.0	53.6	47.0	40.9	33.8						
	EVM8 8N/3	3 + 3		12.6	89				85.0	83.2	80.2	72.5	64.8	55.0	45.8						
	EVM8 10N/4	4 + 4		16.4	111				106.0	103.2	98.4	87.8	79.8	67.5	56.5						
	EVM8 11N/4	4 + 4		16.4	122				116.2	113.2	108.0	97.8	88.0	74.5	61.4						
	EVM16 3F/3	3 + 3		12.6	48							43.6	42.0	40.0	38.1	36.0	30.7	23.8	15.4		
	EVM16 4F/4	4 + 4		16.4	64							58.2	56.4	54.4	52.0	49.7	42.3	33.4	22.3		
	EVM16 5F/5.5	5.5 + 5.5		23	81							73.8	71.5	69.0	67.1	63.7	54.9	43.6	29.5		
	EVM16 6F/5.5	5.5 + 5.5		23	97							88.3	85.3	82.2	79.8	75.8	65.0	52.3	35.8		
	EVM16 7F/7.5	7.5 + 7.5		30.6	113							103.3	99.5	96.0	92.5	88.2	76.5	60.0	41.3		

PERFORMANCE CHART FOR BOTH PUMPS WORKING AT THE SAME TIME

Type of pump	kW	Ass.max (A) Three-phase 400 V	l/min m³/h	Q=Flow rate															
Three-phase 400 V				0	200	300	400	500	600	666	800	900	1000	1100	1200	1400	1600	2000	2400
				H=Discharge head in mwc															
EVM(G) 30 2F/4	4 + 4	16.4		41.5	39.8	39	38.2	37.6	36.0	34.8	32.7	30.4	28.1	25	21.5				
EVM(G) 30 3F/5.5	5.5 + 5.5	23		62	59.1	58	56.2	54.0	52.5	50.5	47.2	44.0	40	35.5	30				
EVM(G) 30 4F/7.5	7.5 + 7.5	30.6		84	80.8	79.8	77.4	75.0	72.6	70.0	65.6	61.0	55.5	49	42				
EVM(G) 30 5F/11	11 + 11	40.8		101	98.7	97.7	95.0	92.0	89.0	86.0	80.1	75.0	67.7	60	52.3				
EVM(G) 30 6F/11	11 + 11	40.8		118	116.5	115.0	112.6	109.8	105.4	102.5	94.6	87.0	79.8	71.5	62.5				
EVM(G) 60 3F/7.5	7.5 + 7.5	30.6		46.6							43.0	42	41.5	40.5	39.3	37	34.5	28.3	19.5
EVM(G) 60 4F/11	11 + 11	40.8		64.5							59.5	58	57	56	54.4	52	48	40	38.5
EVM(G) 60 5F/15	15 + 15	55.2		77.3							71.5	70	68.5	67	65.6	62.3	57.8	48	34.3
EVM(G) 60 6F/15	15 + 15	55.2		90							83.5	82	80	78	76.7	73	67.5	56	40
EVM(G) 60 7F/18.5	18.5 + 18.5	64		110							103.5	102	100	97.5	95.5	90	84	69.5	52

DIMENSION DRAWINGS

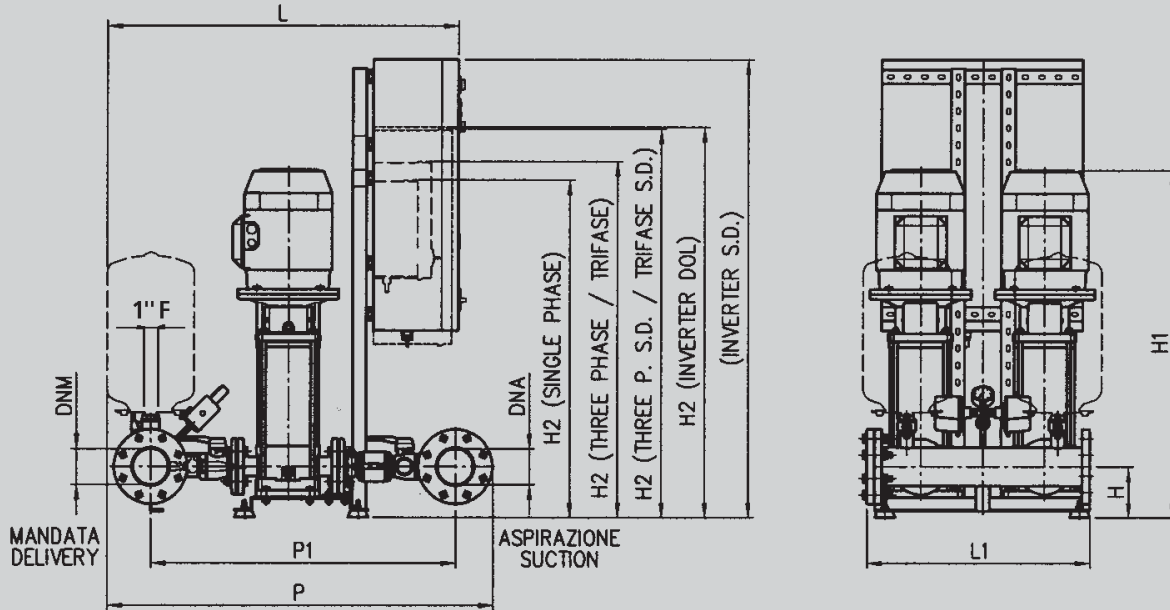

SIN. PH. = Single-phase T.S.D. = Three-phase Star Delta
 D.O.L. = Direct On Line I = Inverter speed control

MODEL	L										H1		H2					P		P1		DNA	WEIGHT kg											
	STANDARD VERSION					AISI 304 VERSION					H	SIN. PH.		STANDARD VERSION					AISI 304 VERSION					L1	DNM									
	SIN. PH.	D.O.L.	T.S.D.	I.D.O.L.	I.S.D.	SIN. PH.	D.O.L.	T.S.D.	I.D.O.L.	I.S.D.		SIN. PH.	D.O.L.	T.S.D.	I.D.O.L.	I.S.D.	SIN. PH.	D.O.L.	T.S.D.	I.D.O.L.	I.S.D.		SIN. PH.			D.O.L.	T.S.D.	I.D.O.L.	I.S.D.					
2GP EVM 4N0,55	830	870	-	-	-	920	960	-	-	-	110	515	535	895	900	-	-	-	895	900	-	-	-	780	1005	690	925	660	G 2	90	92	-	-	-
2GP EVM 5N0,55	830	870	-	-	-	920	960	-	-	-	110	535	555	895	900	-	-	-	895	900	-	-	-	780	1005	690	925	660	G 2	98	100	-	-	-
2GP(E) EVM2 6N0,75	830	870	-	950	-	920	960	-	1040	-	110	595	615	895	900	-	1050	-	895	900	-	1100	-	780	1005	690	925	660	G 2	105	105	-	125	-
2GP(E) EVM2 7N0,75	830	870	-	950	-	920	960	-	1040	-	110	615	635	895	900	-	1050	-	895	900	-	1100	-	780	1005	690	925	660	G 2	105	105	-	130	-
2GP(E) EVM2 9N1,1	830	870	-	950	-	920	960	-	1040	-	110	655	675	895	900	-	1050	-	895	900	-	1100	-	780	1005	690	925	660	G 2	115	115	-	135	-
2GP(E) EVM2 1 1N1,1	830	870	-	950	-	920	960	-	1040	-	110	700	720	895	900	-	1050	-	895	900	-	1100	-	780	1005	690	925	660	G 2	125	120	-	145	-
2GP(E) EVM4 5N1,1	795	835	-	915	-	855	895	-	975	-	110	610	630	895	900	-	1050	-	895	900	-	1100	-	720	885	630	805	660	G 2	115	110	-	135	-
2GP(E) EVM4 6N1,1	795	835	-	915	-	855	895	-	975	-	110	635	655	895	900	-	1050	-	895	900	-	1100	-	720	885	630	805	660	G 2	115	110	-	130	-
2GP(E) EVM4 7N1,5	795	835	-	915	-	855	895	-	975	-	110	705	710	895	900	-	1050	-	895	900	-	1100	-	720	885	630	805	660	G 2	135	125	-	145	-
2GP(E) EVM4 8N1,5	795	835	-	915	-	855	895	-	975	-	110	735	740	895	900	-	1050	-	895	900	-	1100	-	720	885	630	805	660	G 2	140	130	-	150	-
2GP(E) EVM4 10N2,2	-	835	-	915	-	-	895	-	975	-	110	-	820	-	900	-	1050	-	-	900	-	1100	-	720	885	630	805	660	G 2	-	145	-	170	-
2GP(E) EVM4 1 1/2,2	-	835	-	915	-	-	895	-	975	-	110	-	850	-	900	-	1050	-	-	900	-	1100	-	720	885	630	805	660	G 2	-	155	-	175	-
2GP(E) EVM4 12/2,2	-	835	-	915	-	-	895	-	975	-	110	-	890	-	900	-	1050	-	-	900	-	1100	-	720	885	630	805	660	G 2	-	160	-	175	-
2GP(E) EVM8 4N1,5	855	895	-	975	-	925	965	-	1045	-	140	700	705	995	1000	-	1100	-	995	1000	-	1150	-	850	1050	735	935	670	G 3	170	160	-	180	-
2GP(E) EVM8 5N2,2	-	895	-	975	-	-	965	-	1045	-	140	-	765	-	1000	-	1100	-	-	1000	-	1150	-	850	1050	735	935	670	G 3	-	165	-	190	-
2GP(E) EVM8 6N2,2	-	895	-	975	-	-	965	-	1045	-	140	-	795	-	1000	-	1100	-	-	1000	-	1150	-	850	1050	735	935	670	G 3	-	175	-	195	-
2GP(E) EVM8 8N3,0	-	895	-	975	-	-	965	-	1045	-	140	-	890	-	1000	-	1100	-	-	1000	-	1150	-	850	1050	735	935	670	G 3	-	180	-	200	-
2GP(E) EVM8 10N4,0	-	895	-	975	-	-	965	-	1045	-	140	-	980	-	1000	-	1100	-	-	1000	-	1150	-	850	1050	735	935	670	G 3	-	190	-	215	-
2GP(E) EVM8 1 1N4,0	-	895	-	975	-	-	965	-	1045	-	140	-	1010	-	1000	-	1100	-	-	1000	-	1150	-	850	1050	735	935	670	G 3	-	195	-	215	-
2GP(E) EVM16 3F/2,0	-	965	-	1045	1045	-	1095	-	1175	1175	150	-	780	-	1050	-	1150	-	-	1050	-	1150	-	1125	1370	905	1150	690	DN 100	-	265	-	285	-
2GP(E) EVM16 4F/4,0	-	965	-	1045	1045	-	1095	-	1175	1175	150	-	820	-	1050	-	1150	-	-	1050	-	1150	-	1125	1370	905	1150	390	DN 100	-	295	-	320	-
2GP(E) EVM16 5F/5,5	-	965	-	1045	1045	-	1095	-	1175	1175	150	-	945	-	1050	-	1150	-	-	1050	-	1150	-	1125	1370	905	1150	390	DN 100	-	320	-	355	-
2GP(E) EVM16 6F/5,5	-	965	-	1045	1045	-	1095	-	1175	1175	150	-	985	-	1050	-	1150	-	-	1050	-	1150	-	1125	1370	905	1150	390	DN 100	-	385	-	420	-
2GP(E) EVM16 7F/7,5	-	965	1025	1045	1045	-	1095	1155	1175	1175	150	-	1025	-	1050	1145	1150	1350	-	1050	-	1150	1350	1125	1370	905	1150	690	DN 100	-	395	405	430	430

DIMENSION DRAWINGS

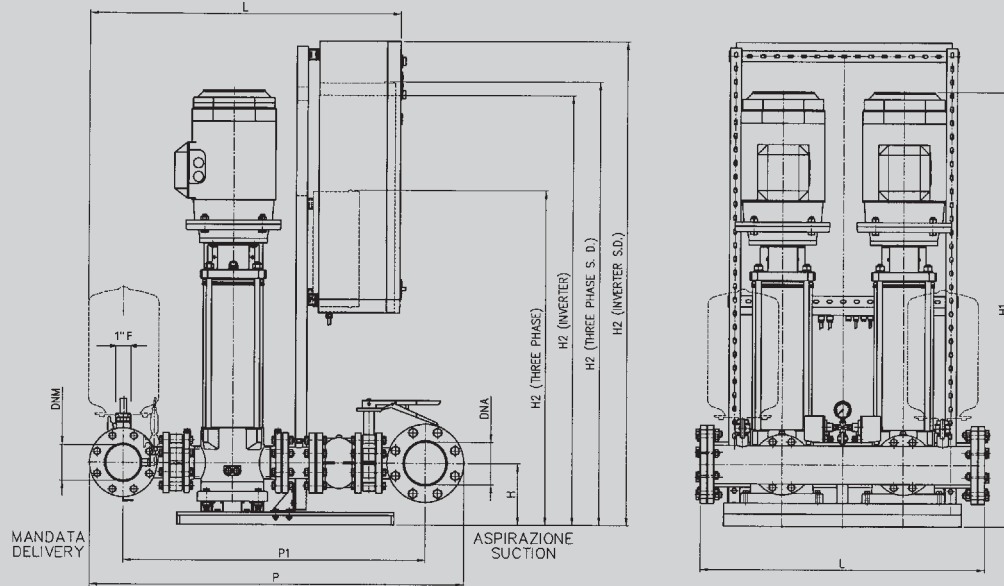

MODEL	L				H	H1		H2				P	P1	L1	DNA	DNM	WEIGHT kg			
	D.O.L.	T.S.D.	I.D.O.L.	I.S.D.		D.O.L./T.S.D.	I.D.O.L./I.S.D.	D.O.L.	T.S.D.	I.D.O.L.	I.S.D.						D.O.L.	T.S.D.	I.D.O.L.	I.S.D.
2GP(E) EVMG 30 2F/4,0	1065	-	1165	-	190	890	1025	-	1275	-	1340	1105	1050	DN125	DN100	405	-	135	-	
2GP(E) EVMG 30 3F/5,5	1065	-	1165	-	190	1025	1025	-	1275	-	1340	1105	1050	DN125	DN100	460	-	500	-	
2GP(E) EVMG 30 4F/7,5	1065	1145	1165	1165	190	1070	1025	1325	1275	1475	1340	1105	1050	DN125	DN100	480	490	520	520	
2GP(E) EVMG 30 5F/11	1065	1145	1215	1215	190	1275	1275	1325	1475	1475	1340	1105	1050	DN125	DN100	580	590	640	640	
2GP(E) EVMG 30 6F/1 I	1065	1145	1215	1215	190	1325	1275	1325	1475	1475	1340	1105	1050	DN125	DN100	580	590	640	650	
2GP(E) EVMG 60 3F/7,5	995	1055	1100	1100	225	1150	1175	1375	1375	1575	1385	1115	1050	DN150	DN125	520	530	560	560	
2GP(E) EVMG 60 4F/1 I	995	1055	1130	1150	225	1375	1225	1375	1575	1575	1385	1115	1050	DN150	DN125	620	630	680	680	
2GP(E) EVMG 60 5F/15	-	1055	-	1150	225	1450	-	1475	-	1575	1385	1115	1050	DN150	DN125	-	680	620	710	
2GP(E) EVMG 60 6F/15	-	1055	-	1150	225	1520	-	1475	-	1575	1385	1115	1050	DN150	DN125	-	690	630	720	
2GP(E) EVMG 60 7F/18,5	-	1105	-	1150	225	1590	-	1625	-	1775	1385	1115	1050	DN150	DN125	-	730	660	760	

SIN. PH. = Single-phase
D.O.L. = Direct On Line

T.S.D. = Three-phase Star Delta
I = Inverter speed control



*Tanks optional

UNITS WITH TWO HORIZONTAL CLOSE-COUPLED PUMPS STANDARDIZED TO EN733 (FORMER DIN 24255), WITH STAINLESS STEEL HYDRAULIC PARTS, "3M" SERIES



*Tanks optional

TYPICAL APPLICATIONS

The unit's base plate is in galvanized steel, as are the manifolds. The delivery manifold is supplied ready to accommodate 2 vertical diaphragm tanks, where needed. It has 2 pressure switches, the control board and a pressure gauge fitted. Each motor-driven pump has an isolating valve and a nonreturn valve on the suction line, with the option of connecting an air supplier, and features another isolating valve on the delivery.

The control panel is supported by a special mount fastened to the base plate.

PROTECTION AND CONTROL BOARD WITH CE MARK

- Components are IMQ and VDE certified.
- Very low voltage auxiliary circuit.
- Motors are switched on and off by two pressure switches.
- Float switches, or a minimum pressure switch, can be connected to prevent operation when there is no water in suction line.
- There is a device alternating the order pumps come on every time they are started.
- Power supply: - three-phase 400 V, 50Hz.
- Starting: - direct-on-line for wattages up to 7.5 kW
- star-delta for wattages over 7.5 kW
- Fuses protecting power circuit.
- Fuses protecting auxiliary circuit.
- IP rating IP 55.
- Master line disconnecter with door lock.
- Auto - 0 - Hand switches for each pump.
- Thermal overload cutout reset.
- Indicator LED: - mains power
- motor running
- level alarm
- motor cutout tripped
(for three-phase version only).
- Output provided for alarm warning.
- Special-version boards can be used on request.

THEORY OF OPERATION

If water is taken from the system, or leaks, with the pumps stopped, pressure drops and the contact of the pressure switch with the highest setting consequently closes, causing the first motor-driven pump to start. If the flow out is higher than the capacity of one pump, pressure will continue to drop until it causes the contact of the second pressure switch to close and hence the second pump to start. When delivery ends or the output flow is reduced, pressure in the system is raised, causing the contacts of the pressure switches to open and the pumps to stop in sequence. Reversing the order in which the two motors come on reduces the number of times the individual pumps start per hour and ensures both are used.

Connecting a float switch or minimum pressure switch to the control panel (both for drawing from the primary storage tank and from the water circuit) will prevent the most frequent cause of motor-driven pump failure: lack of water in suction line.

2GP 3M 32 PERFORMANCE CURVES (according to ISO 9906 Annex A)

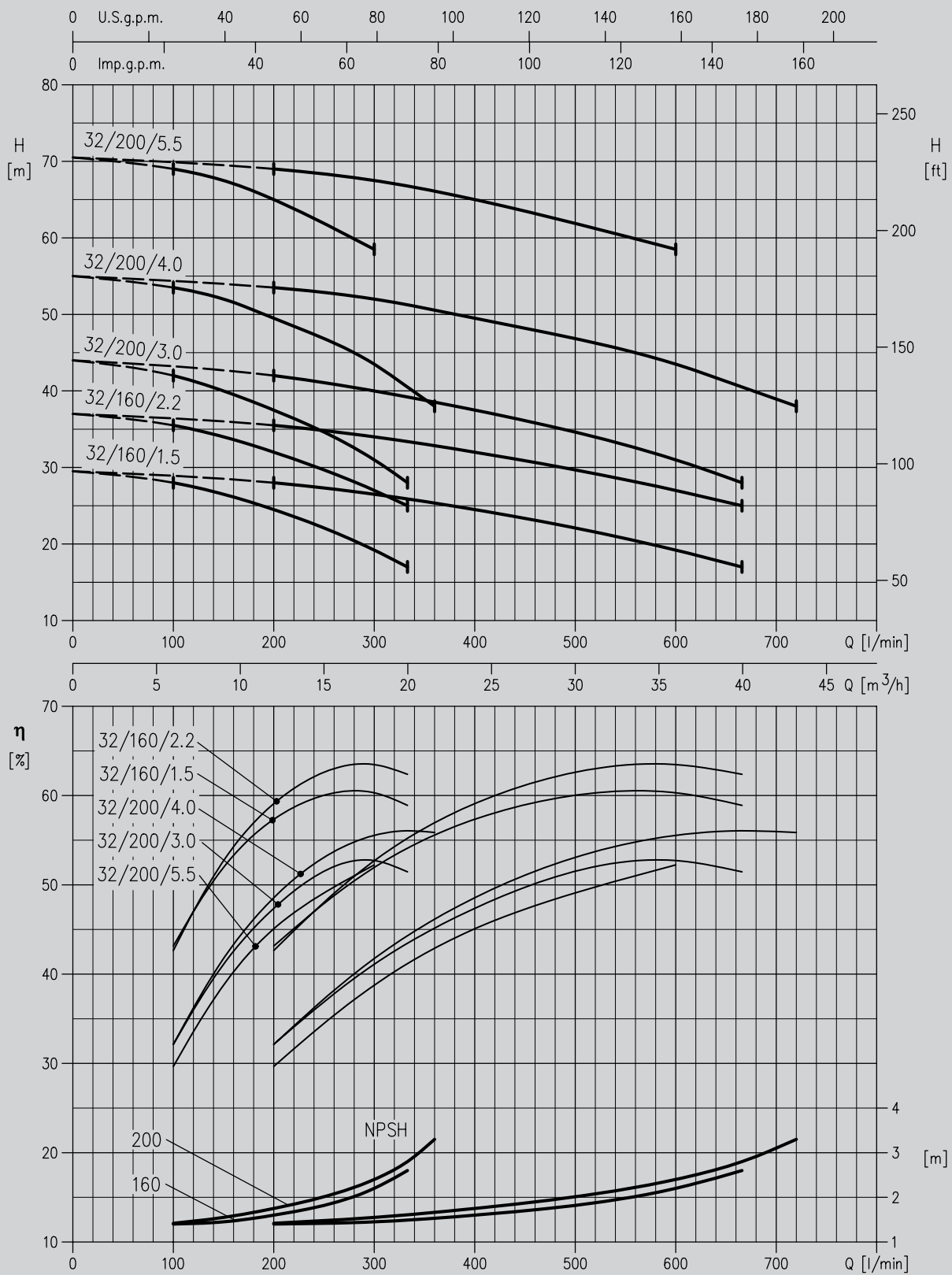

2GP 3M 40 PERFORMANCE CURVES (according to ISO 9906 Annex A)

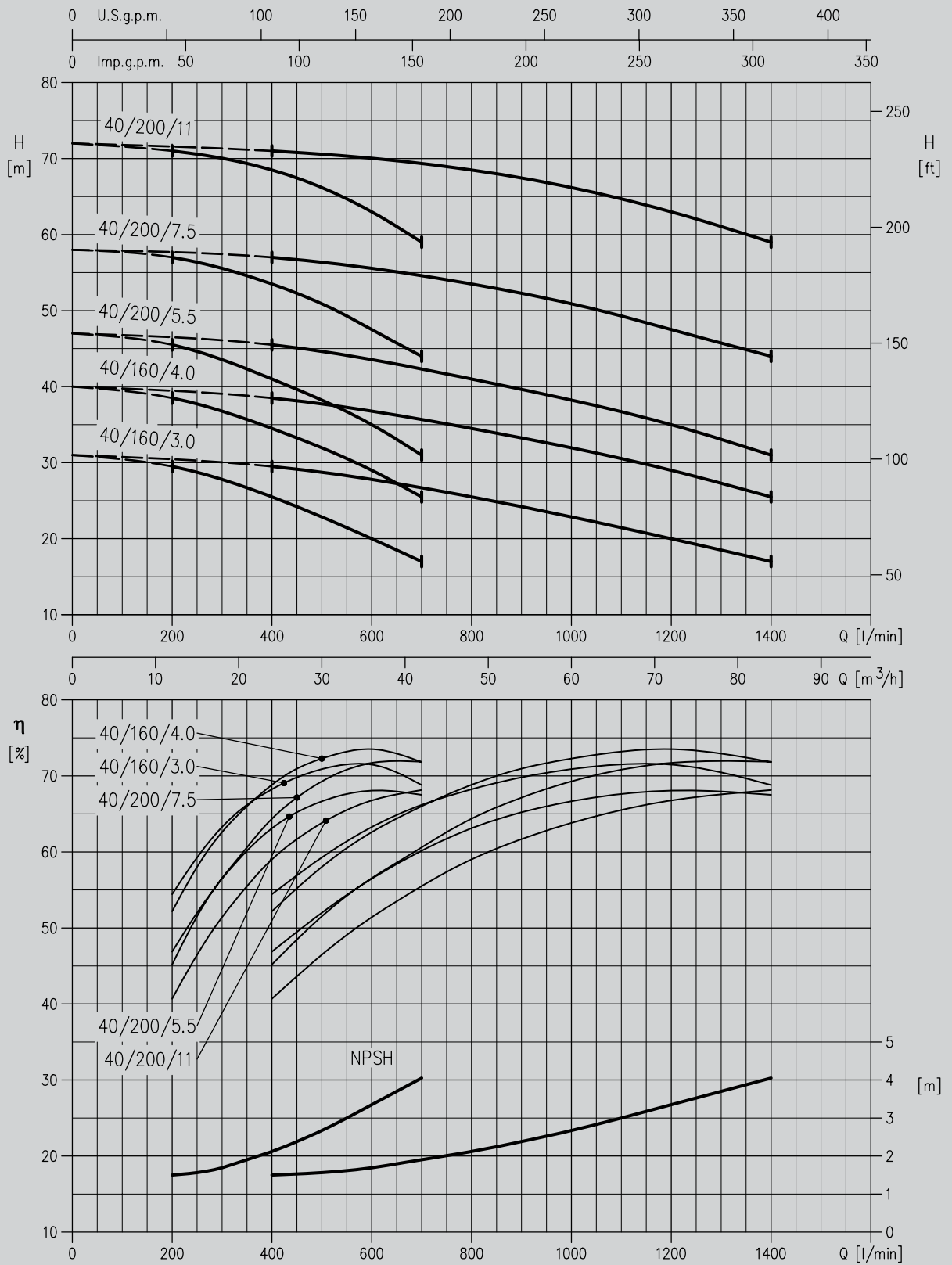

2GP 3M 50 PERFORMANCE CURVES (according to ISO 9906 Annex A)

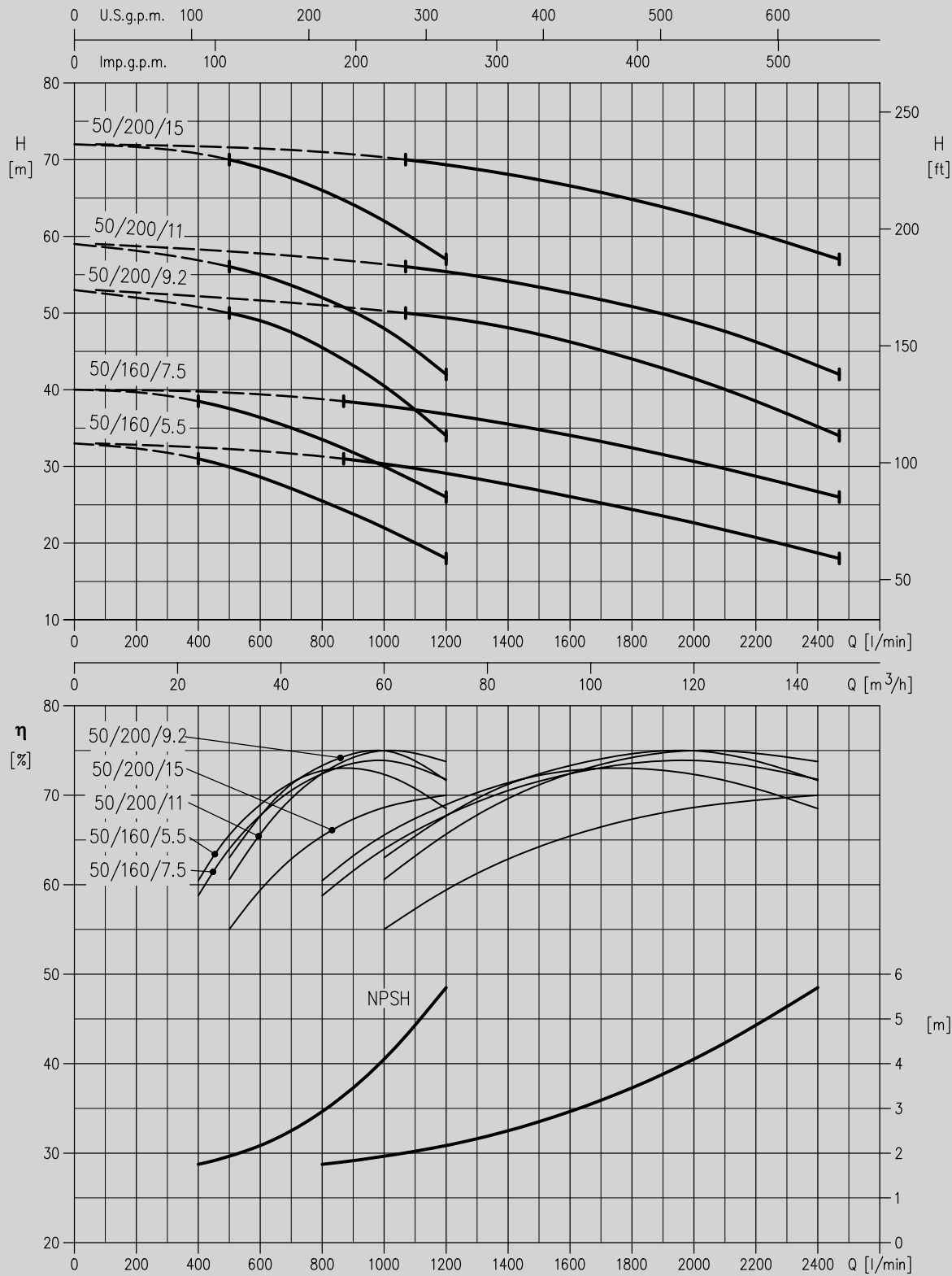

PERFORMANCE TABLE OF THE PUMPS WORKING TOGETHER

Type of pump	kW	Absorbed current (A)	Q=Capacity																
			l/min	0	200	300	400	600	666	720	800	900	1000	1200	1400	1600	2000	2400	
Three-phase 400 V			m ³ /h	0	12	18	24	36	40	43	48	54	60	72	84	96	120	144	
				H = total head (m)															
3M 32-160/1.5	1.5 + 1.5	6.8		29.5	28	26.5	24.5	19.2	17										
3M 32-160/2.2	2.2 + 2.2	9.6		37	35.5	34	32	27	25										
3M 32-200/3	3 + 3	13.6		44	42	40	37.5	31	28										
3M 32-200/4	4 + 4	18		55	53.5	52	49.5	43.5	40.5	38									
3M 32-200/5.5	5.5 + 5.5	23.6		70.5	69	67.5	65	58.5											
3M 40-160/3	3 + 3	13.6		31			29.5	27.5	27	26.5	25.5	24	22.5	20	17				
3M 40-160/4	4 + 4	18.4		40			38.5	37	36	35.5	34.5	33	32	29	25.5				
3M 40-200/5.5	5.5 + 5.5	22.2		47			45.5	44	43	42.5	41	39.5	38	35	31				
3M 40-200/7.5	7.5 + 7.5	30.2		58			57	55.5	55	54.5	53.5	52.5	51	47.5	44				
3M 40-200/11	11 + 11	40		72			71	70	70	69.5	68.5	67.5	66	63	59				
3M 50-160/5.5	5.5 + 5.5	23		33							31	30.5	30	28.5	27	22.5	22	18	
3M 50-160/7.5	7.5 + 7.5	31		40							38.5	38	37.5	36	35	33.5	30	26	
3M 50-200/9.2	9.2 + 9.2	34.8		53									50	49	47.5	45.5	40.5	34	
3M 50-200/11	11 + 11	44		59									56	55	54	52	48	42	
3M 50-200/15	15 + 15	62.6		72									70	69	68	66	62	57	

DIMENSION DRAWINGS

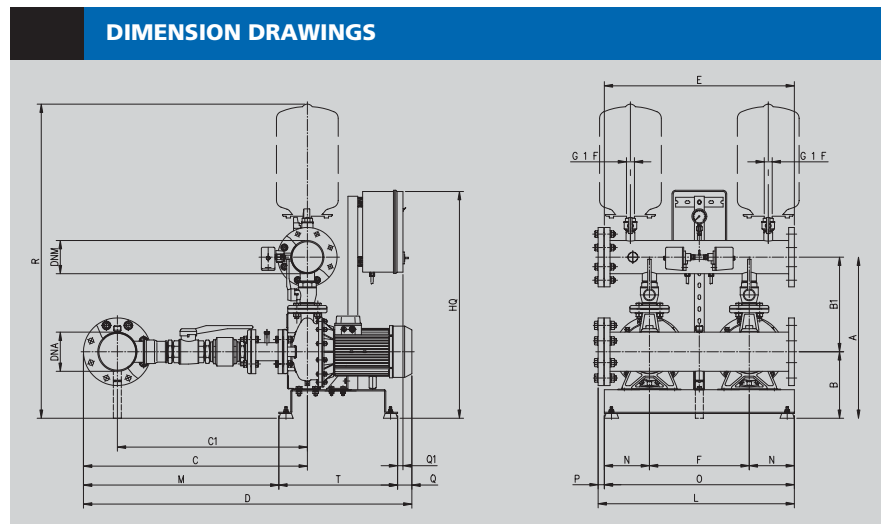

DIMENSION TABLE

Model	Dimensions (mm)																					
	A	B	B1	C	C1	D	DNA	DNM	E	F	HQ	L	M	N	O	P	Q	Q1	R	T	W	
2GP 3M 32-160/1.5	655	250	405	425	380	805	80	65	520	370	765	800	305	215	800	15	1280	500	800	96		
2GP 3M 32-160/2.2											103											
2GP 3M 32-200/3.0											118											
2GP 3M 32-200/4.0	705	280	425	805	680	1205	125	100	800	420	815	825	190	25	1285	15	55	1330	800	133		
2GP 3M 32-200/5.5											155											
2GP 3M 40-160/3.0	605	250	355	785	660	1165	125	100	800	420	955	825	665	190	25	1235	15	15	1285	500	168	
2GP 3M 40-160/4.0																						183
2GP 3M 40-200/5.5	655	280	375	805	680	1245	125	100	800	420	955	825	685	190	25	1285	60	55	1285	500	216	
2GP 3M 40-200/7.5																						230
2GP 3M 40-200/11	620	245				1370					1080	880	570	230	880				1250	800	294	
2GP 3M 50-160/5.5	680	280	400	940	800	1345	150	125	800	420	955	825	820	190	800	25	15	15	1325	500	229	
2GP 3M 50-160/7.5																						243
2GP 3M 50-200/9.2	665	245	420	940	800	1500	150	125	800	420	1080	880	700	230	880				1310	800	269	
2GP 3M 50-200/11																						306
2GP 3M 50-200/15																						360

**UNITS WITH 2 HORIZONTAL
CLOSE-COUPLED PUMPS
STANDARDIZED TO EN733
(FORMER DIN 24255),
WITH CAST IRON HYDRAULIC
PARTS, "MD/MMD" SERIES**



*Tanks optional

TYPICAL APPLICATIONS

The unit's base plate is in galvanized steel, as are the manifolds. The delivery manifold is supplied ready to accommodate 2 vertical diaphragm tanks, where needed. It has 2 pressure switches, the control board and a pressure gauge fitted. Each motor-driven pump has an isolating valve and a nonreturn valve on the suction line, with the option of connecting an air supplier, and features another isolating valve on the delivery. The control panel is supported by a special mount fastened to the base plate.

PROTECTION AND CONTROL BOARD WITH CE MARK

- Components are IMQ and VDE certified.
- Very low voltage auxiliary circuit.
- Motors are switched on and off by two pressure switches.
- Float switches, or a minimum pressure switch, can be connected to prevent operation when there is no water in suction line.
- There is a device alternating the order pumps come on every time they are started.
- Power supply: - three-phase 400 V, 50Hz
- Starting: - direct-on-line for wattages up to 7.5 kW
- star-delta for wattages over 7.5 kW
- Fuses protecting power circuit.
- Fuses protecting auxiliary circuit.
- IP rating IP 55.
- Master line disconnecter with door lock.
- Auto - 0 - Hand switches for each pump.
- Thermal overload cutout reset.
- Indicator LED: - mains power
- motor running
- level alarm
- motor cutout tripped
(for three-phase version only).
- Output provided for alarm warning.
- Special-version boards can be used on request.

THEORY OF OPERATION

If water is taken from the system, or leaks, with the pumps stopped, pressure drops and the contact of the pressure switch with the highest setting consequently closes, causing the first motor-driven pump to start. If the flow out is higher than the capacity of one pump, pressure will continue to drop until it causes the contact of the second pressure switch to close and hence the second pump to start. When delivery ends or the output flow is reduced, pressure in the system is raised, causing the contacts of the pressure switches to open and the pumps to stop in sequence. Reversing the order in which the two motors come on reduces the number of times the individual pumps start per hour and ensures both are used. Connecting a float switch or minimum pressure switch to the control panel (both for drawing from the primary storage tank and from the water circuit) will prevent the most frequent cause of motor-driven pump failure: lack of water in suction line.

2GP MD 32 PERFORMANCE CURVES (according to ISO 9906 Annex A)

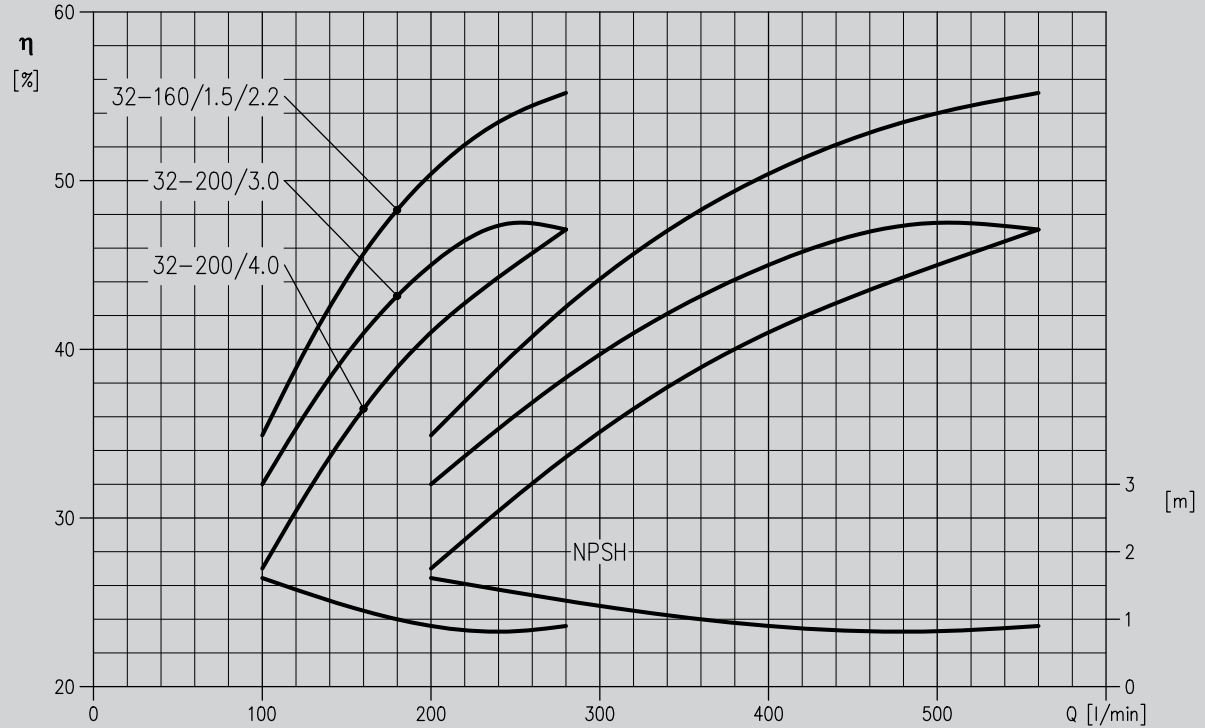
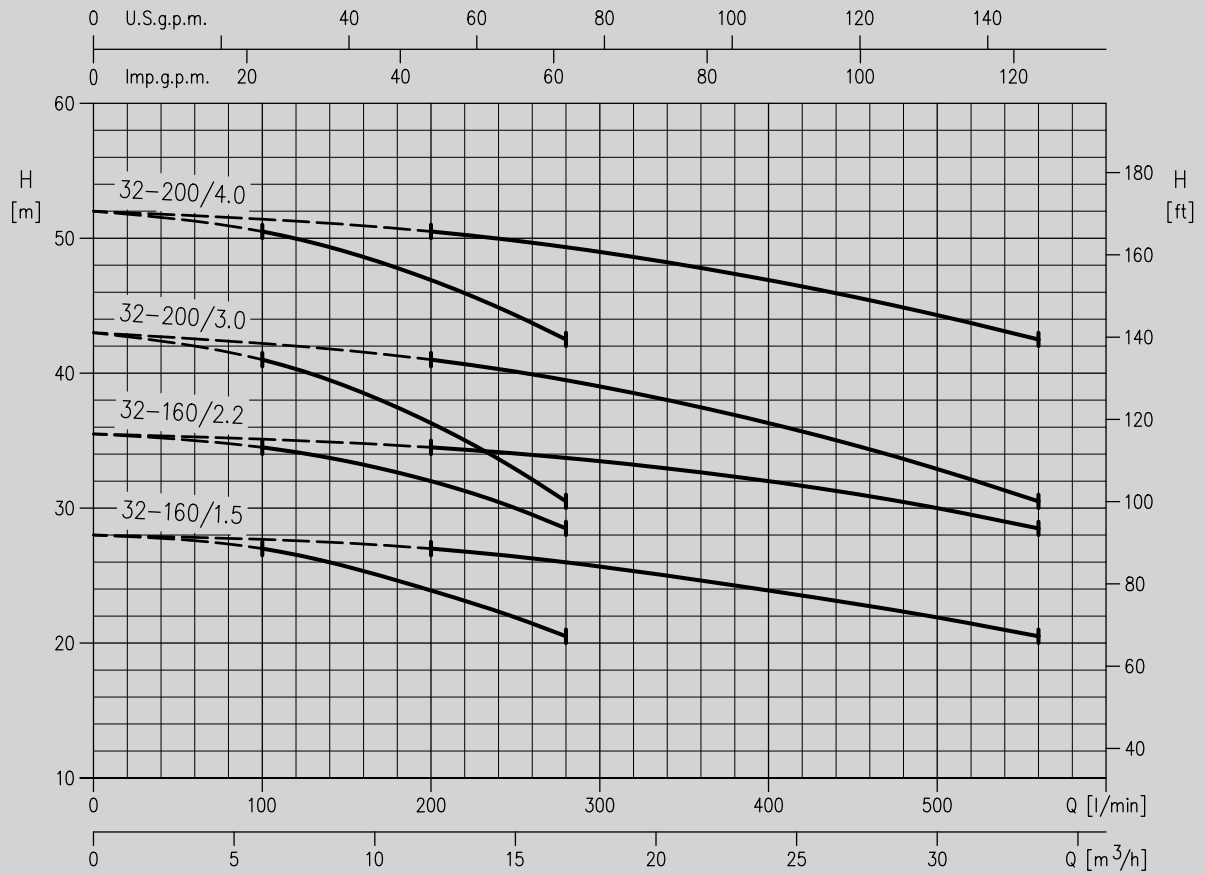



2GP MD 32 PERFORMANCE CURVES (according to ISO 9906 Annex A)

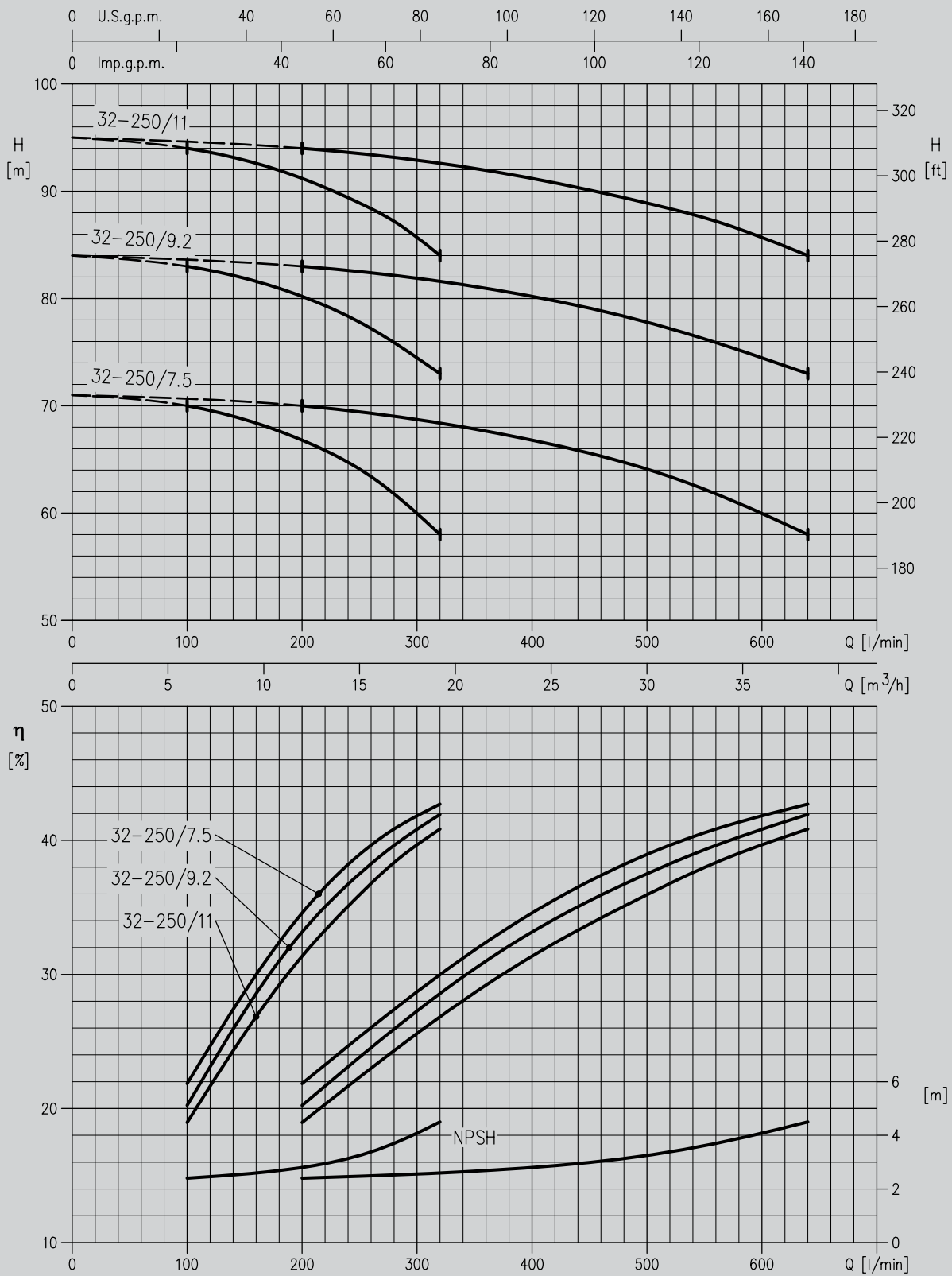

2GP MD 40 PERFORMANCE CURVES (according to ISO 9906 Annex A)

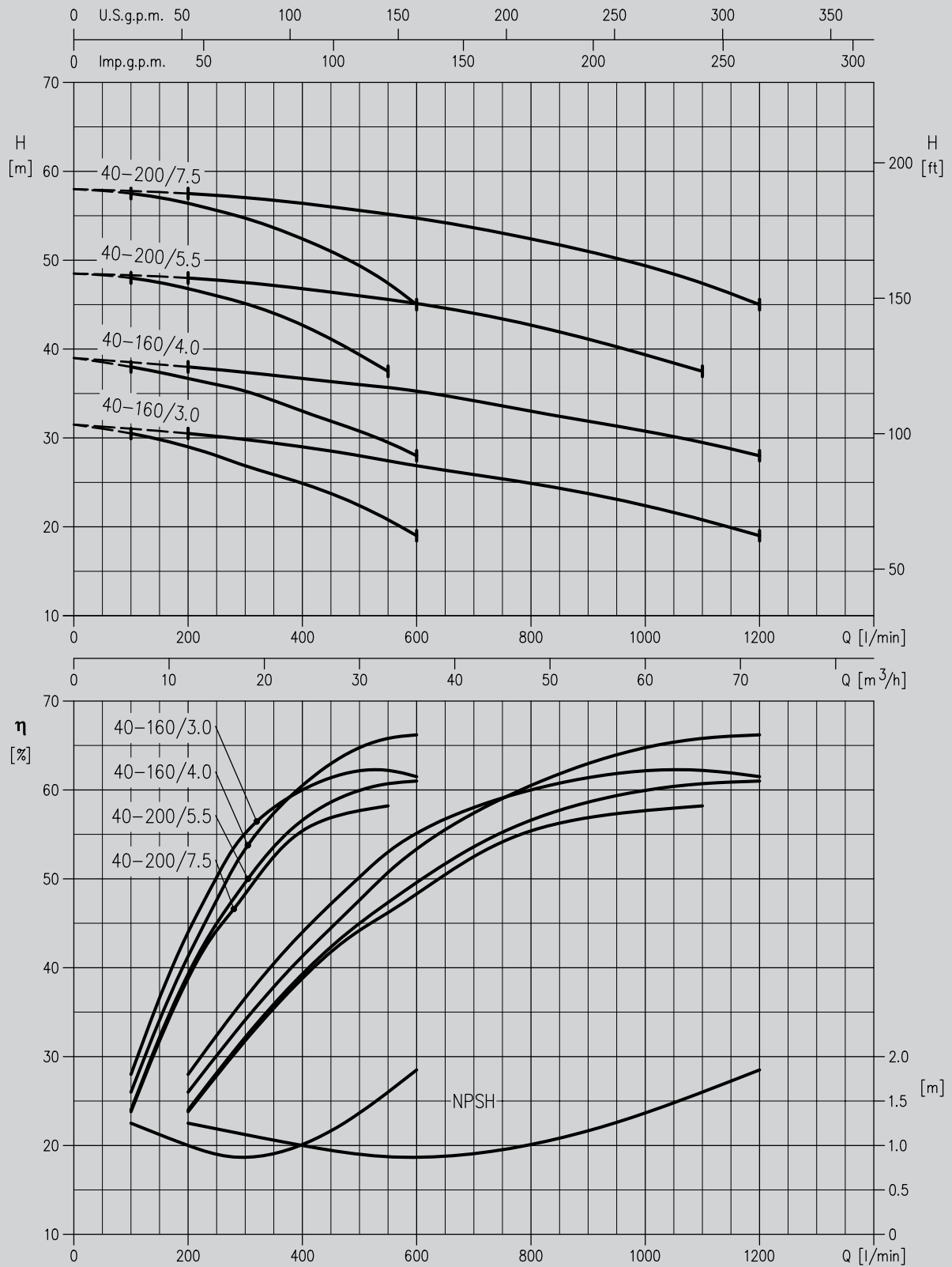



2GP MD 40 PERFORMANCE CURVES (according to ISO 9906 Annex A)

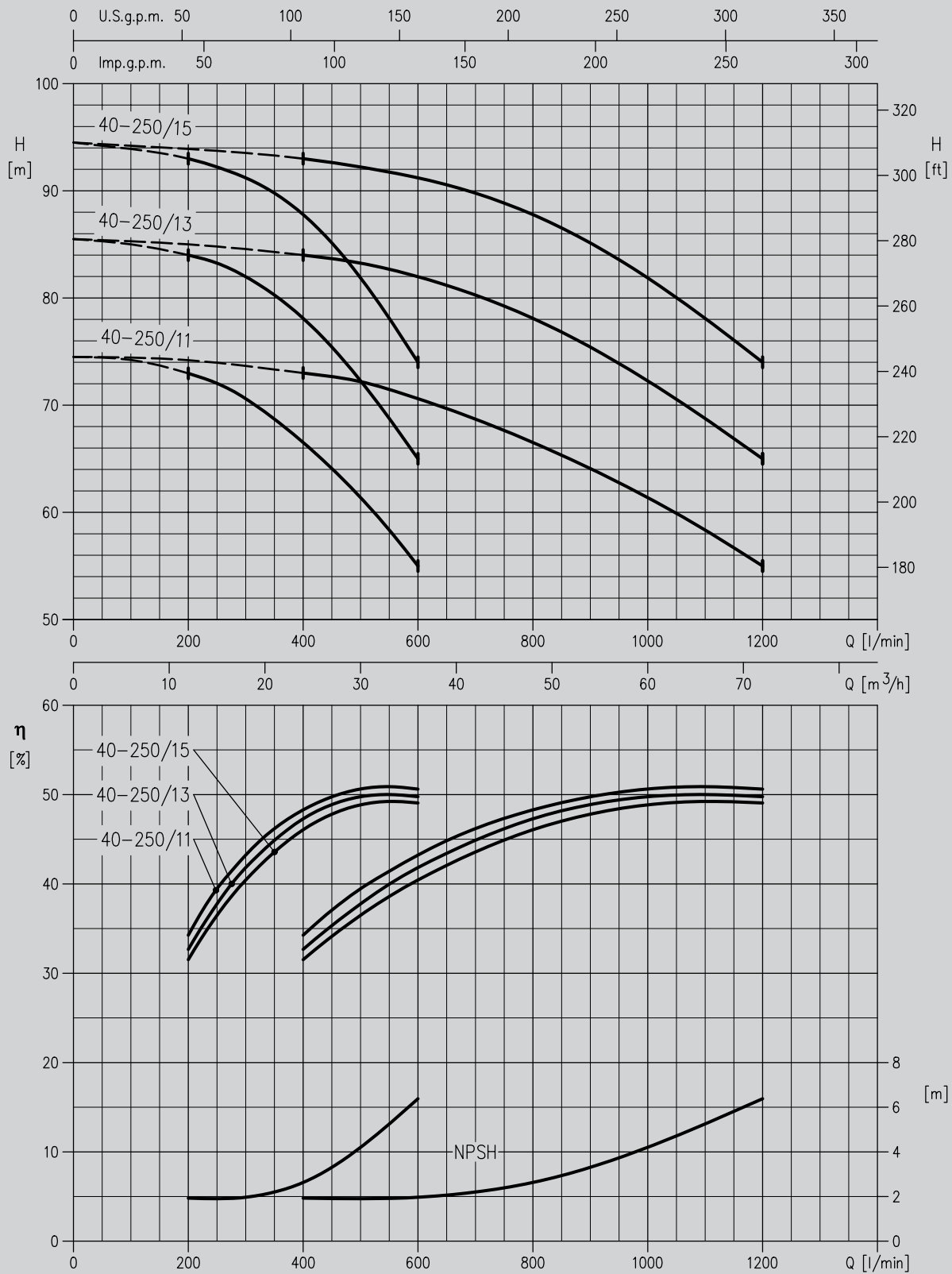

2GP MD 50 PERFORMANCE CURVES (according to ISO 9906 Annex A)

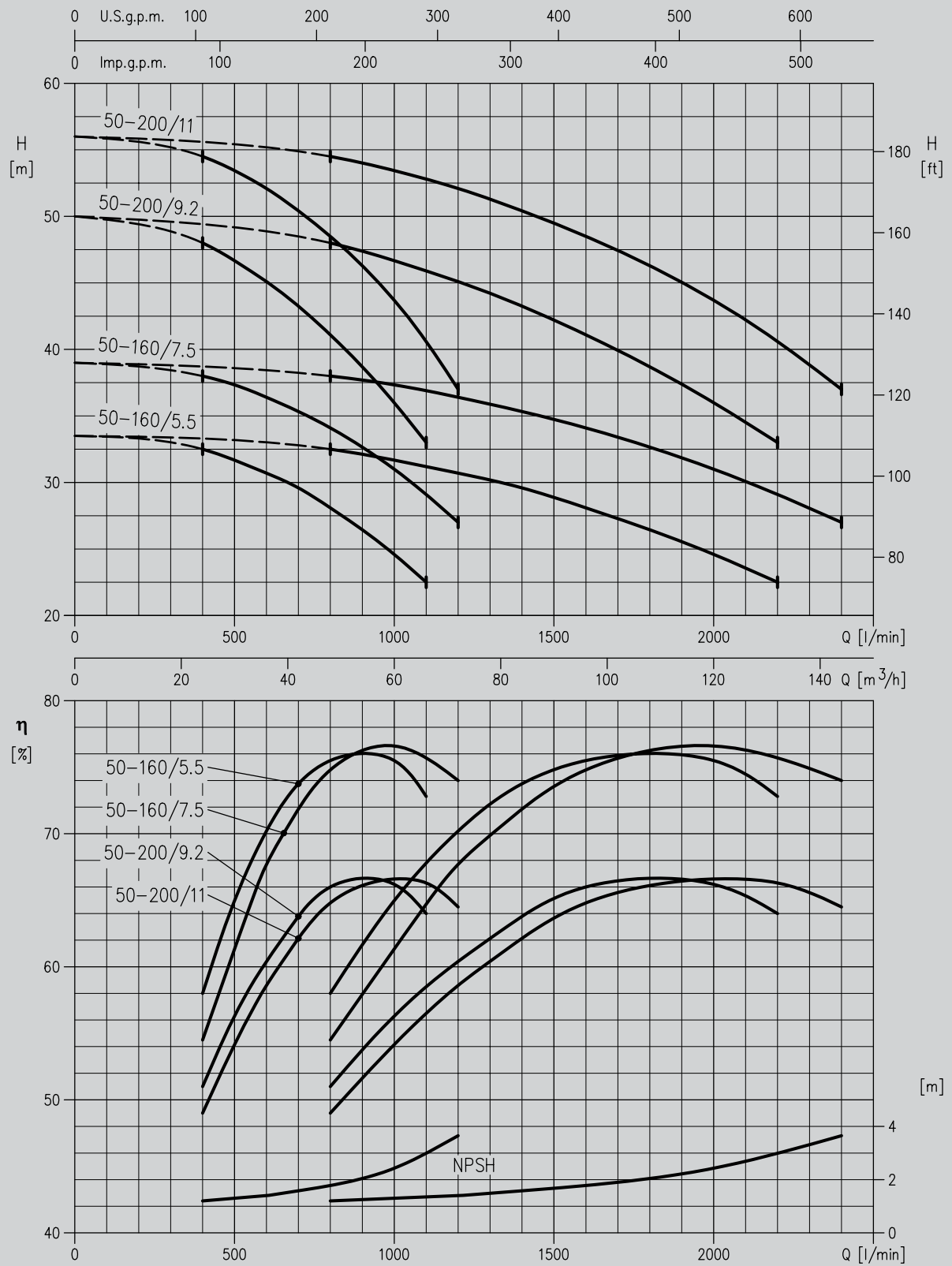



2GP MD 50 PERFORMANCE CURVES (according to ISO 9906 Annex A)

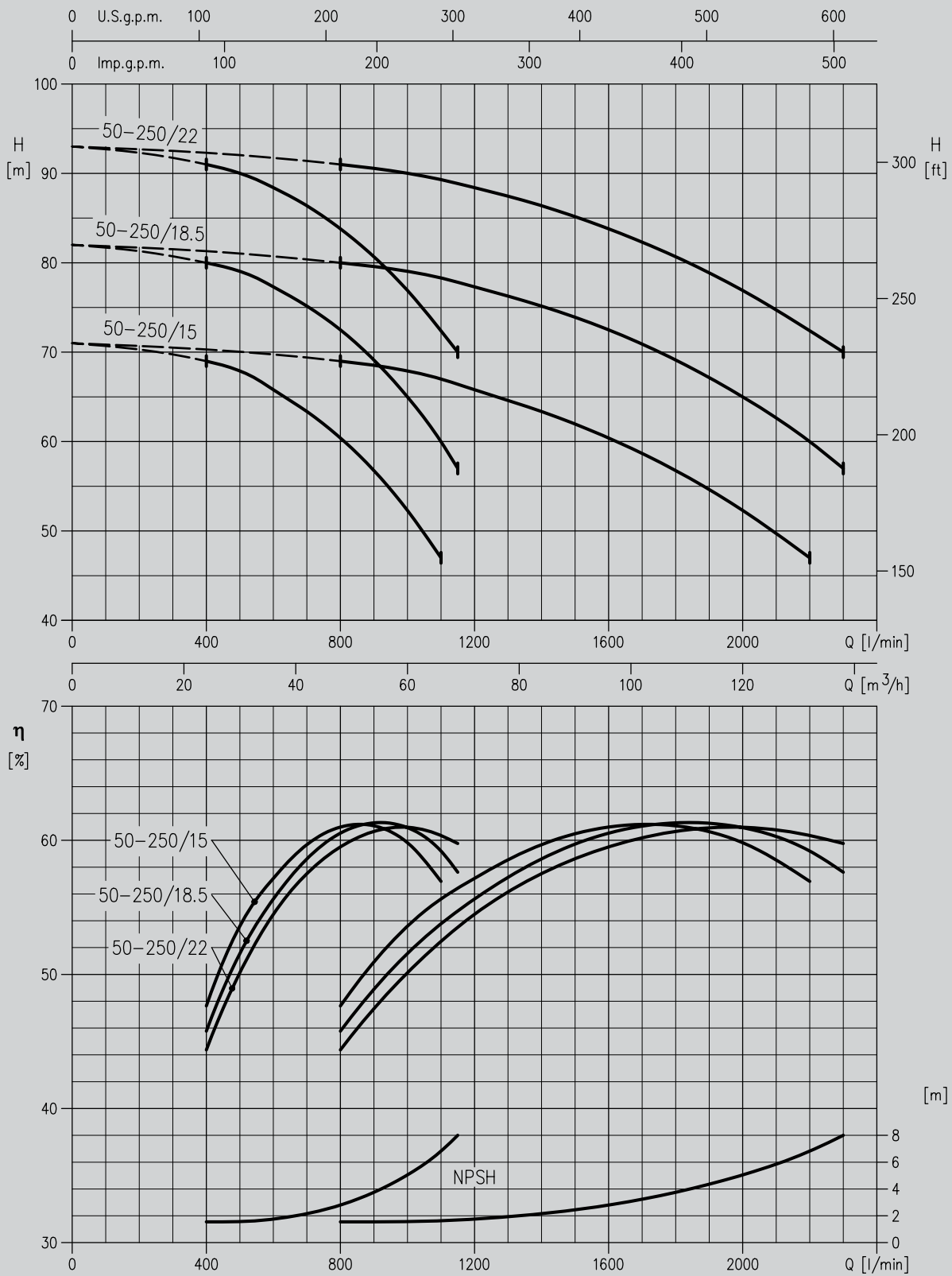

2GP MD 65 PERFORMANCE CURVES (according to ISO 9906 Annex A)

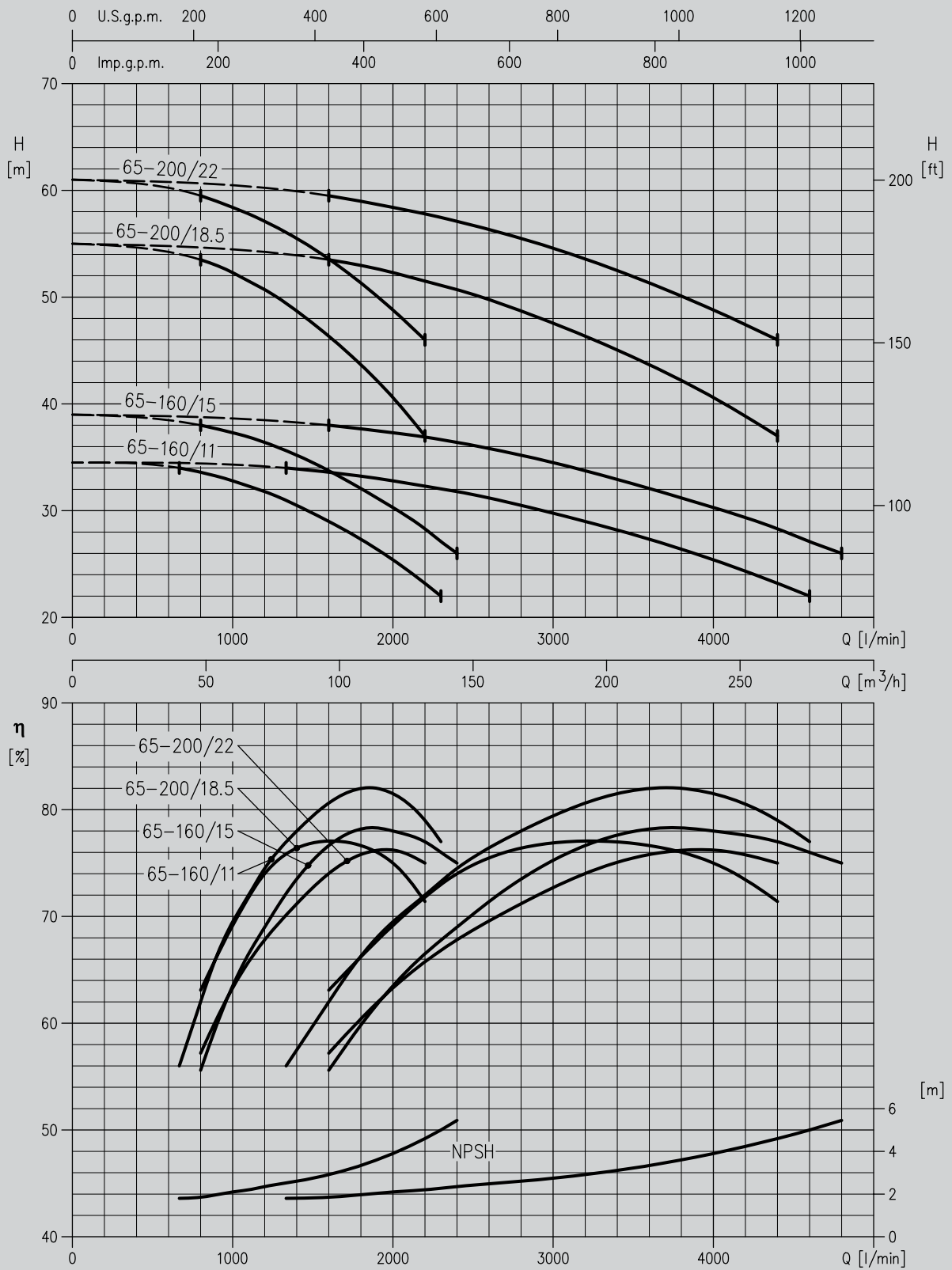



2GP MMD 65 PERFORMANCE CURVES (according to ISO 9906 Annex A)

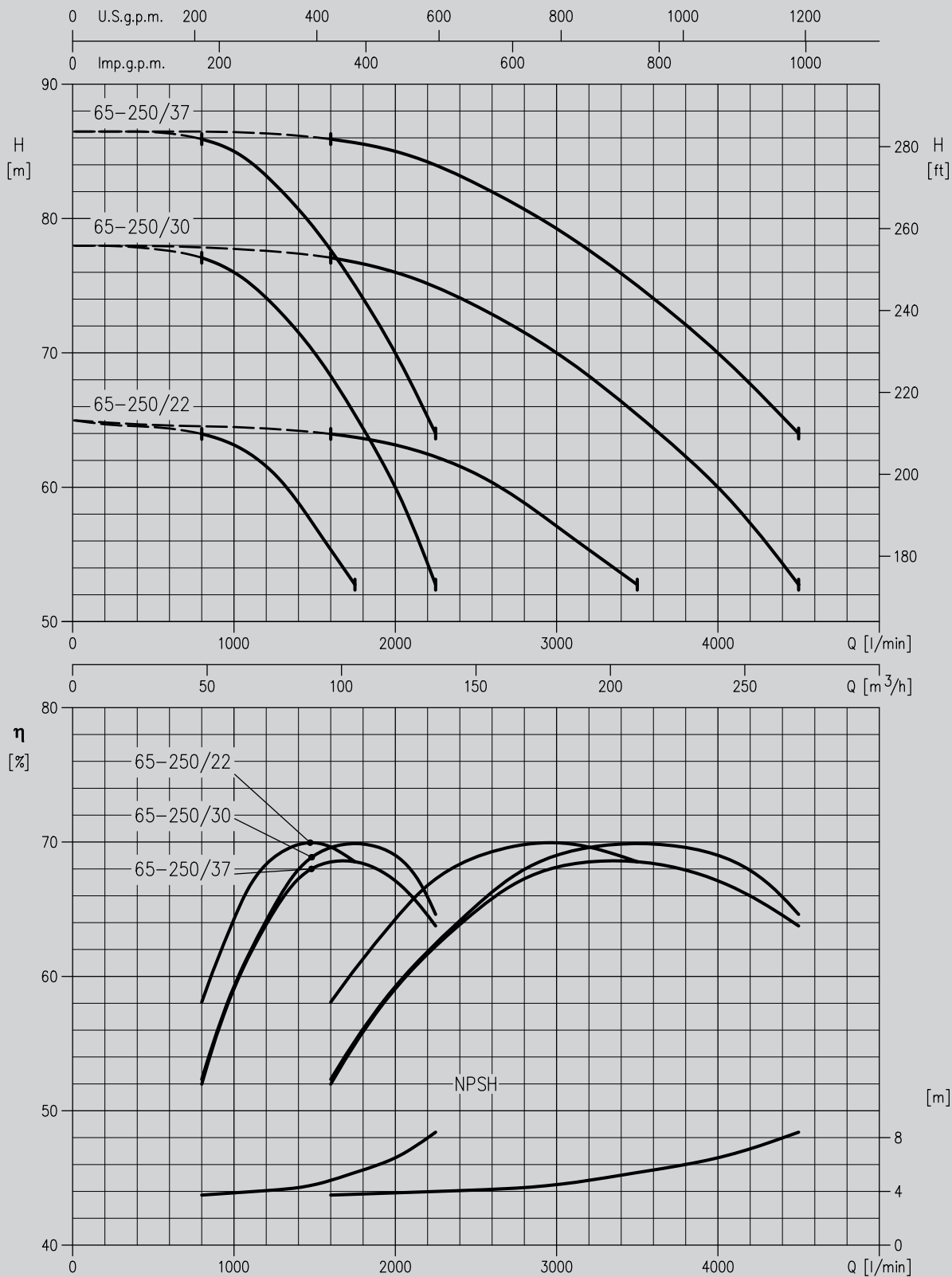

PERFORMANCE TABLE OF THE TWO PUMPS WORKING TOGETHER

Type of pump	Three-phase 400 V	kW	Absorbed current (A)	Q=Capacity																									
				l/min	0	200	400	500	560	640	800	1100	1200	1333	1600	2000	2200	2300	2400	2500	3000	3500	4000	4400	4500	4600	4800		
				m ³ /h	0	12	24	30	34	38	48	66	72	80	96	120	132	138	144	150	180	210	240	264	270	276	288		
				H= total head (m)																									
MD 32-160/1.5	1.5 + 1.5	6.8		28	27	24	22	20.5																					
MD 32-160/2.2	2.2 + 2.2	10		35.5	34.5	32	30	28.5																					
MD 32-200/3	3 + 3	13.8		43	41	36.5	33	30.5																					
MD 32-200/4	4 + 4	18.4		52	50.5	47	44.5	42.5																					
MD 32-250/7.5	7.5 + 7.5	29.2		71	70	67	64	62	58																				
MD 32-250/9.2	9.2 + 9.2	36.6		84	83	80	78	76	73																				
MD 32-250/11	11 + 11	41.4		95	94	91	89	87	84																				
MD 40-160/3	3 + 3	13.2		31.5	30.5	29	28	27.5	26.5	25	21	19																	
MD 40-160/4	4 + 4	19.6		39	38	36.5	36	35.5	35	33	29.5	28																	
MD 40-200/5.5	5.5 + 5.5	23		48.5	48	47	46	45.5	44.5	42.5	37.5																		
MD 40-200/7.5	7.5 + 7.5	31		58	57.5	56.5	55.5	55	54.5	52.5	47.5	45																	
MD 40-250/11	11 + 11	41.2		74.5		73	72	71.5	70	66.5	58.5	55																	
MD 40-250/13	13 + 13	50.6		85.5		84	83.5	82.5	81.5	78	69	65																	
MD 40-250/15	15 + 15	58.2		94.5		93	92	91.5	90.5	88	78	74																	
MD 50-160/5.5	5.5 + 5.5	23.6		33.5						32.5	31	30.5	30	28	24.5	22.5													
MD 50-160/7.5	7.5 + 7.5	30		39						38	37	36.5	35.5	34	31	29	28	27											
MD 50-200/9.2	9.2 + 9.2	38		50						48	46	45	44	41	36	33													
MD 50-200/11	11 + 11	44		56						54.5	53	52	51	48.5	43.5	40.5	39	37											
MD 50-250/15	15 + 15	59.4		71						69	67	66	64	60.5	52.5	47													
MD 50-250/18.5	18.5 + 18.5	75.4		82						80	78.5	77.5	76	72.5	65	60	57												
MD 50-250/22	22 + 22	82		93						91	89.5	88.5	87	84	77	72.5	70												
MD 65-160/11	11 + 11	41.6		34.5									34	33.5	33	32.5	32	32	31.5	29.5	27.5	25.5	23	22.5	22				
MD 65-160/15	15 + 15	54		39										38	37.5	37	36.5	36.5	36	34.5	31.5	30.5	28.5	27.5	27	26			
MD 65-200/18.5	18.5 + 18.5	78		55										53.5	52.5	51.5	51	50.5	50	47.5	44.5	40.5	37						
MD 65-200/22	22 + 22	86		61										59.5	58.5	58	57.5	57	56.5	55	52	49	46						
MMD 65-250/22	22 + 22	89		65										64	63	62.5	62	61.5	61	57	53								
MMD 65-250/30	30 + 30	116		78										77	76	75.5	75	74	74	70	66	60	54	53					
MMD 65-250/37	37 + 37	142		86.5										86	85	84.5	84	83.5	83	79	75	70	65	64					

DIMENSION DRAWINGS

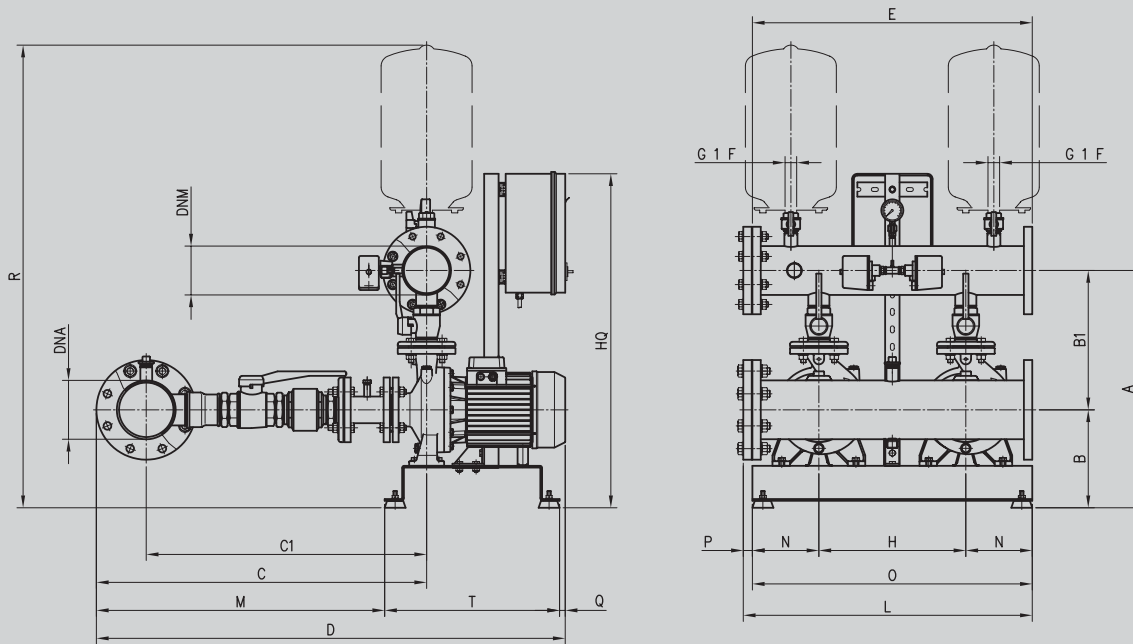

DIMENSION TABLE

Model	Dimensions (mm)																			
	A	B	B1	C	C1	D	E	DNA	DNM	H	HQ	L	M	N	O	P	Q	R	T	W
2GP MD 32 -160/1,5	570	250	320	430	380	805	650	G3	G3	350	955	800	305	225	800		5	1190	500	135
2GP MD 32 -160/2.2																				140
2GP MD 32 -200/3.0	620	280	340			810					955	800	305	225	800		75	1240	500	155
2GP MD 32 -200/4.0																				165
2GP MD 32 -250/7.5																				200
2GP MD 32 -250/9.2	650	265	385	450	400	890					1175	880	200	265	880		75	1305	800	230
2GP MD 32 -250/11																				242
2GP MD 40 -160/3.0	605	250	355	785	660	1165					955	825	665	190	800	25	15	1235	500	200
2GP MD 40 -160/4.0																				210
2GP MD 40 -200/5.5	655	280	375			1200		125	100		955	825	685	230	880		15	1285	800	240
2GP MD 40 -200/7.5																				250
2GP MD 40 -250/11																				286
2GP MD 40 -250/13	685	265	420	805	680	1360					1175	880	560	230	880			1315	800	330
2GP MD 40 -250/15																				340
2GP MD 50 -160/5.5	680	280	400			1340					955	825	825	190	800	25	15	1325	500	245
2GP MD 50 -160/7.5																				267
2GP MD 50 -200/9.2	665	245	420	945	800	1500	800	150	125	420	1155		700					1310	800	302
2GP MD 50 -200/11																				317
2GP MD 50 -250/15																				340
2GP MD 50 -250/18.5	710	265	445			1650					1260		850				1355	800	362	
2GP MD 50 -250/22																			370	
2GP MD 65 -160/11	900	245	655			1635					1155		835	230				1585	800	397
2GP MD 65 -160/15																				432
2GP MD 65 -200/18.5	945	265	680	1080	880	1775		250	200		1380		975					1630	800	520
2GP MD 65 -200/22																				535
2GP MMD 65 -250/22																				540
2GP MMD 65 -250/30	995	285	710			1885					1510		1085					1675	800	615
2GP MMD 65 -250/37																				665

www.ebara.eu



EBARA PUMPS EUROPE S.p.A.
Via Pacinotti, 32
36040 BRENDOLA (VICENZA), Italy
Phone: +39-0444-706811
Fax: +39-0444-706950
Plants: Cles, Brendola
www.ebara.eu

cod. 479705326 REV. 01/05

EBARA PUMPS EUROPE S.p.A. reserves the right to make modifications without prior notice: all specifications could be subject to change